

ComblCAO Applet v2.1 in SSCD configuration on Cosmo V9.2

Public Security Target



About IDEMIA

OT-Morpho is now IDEMIA, the global leader in trusted identities for an increasingly digital world, with the ambition to empower citizens and consumers alike to interact, pay, connect, travel and vote in ways that are now possible in a connected environment.

Securing our identity has become mission critical in the world we live in today. By standing for Augmented Identity, we reinvent the way we think, produce, use and protect this asset, whether for individuals or for objects. We ensure privacy and trust as well as guarantee secure, authenticated and verifiable transactions for international clients from Financial, Telecom, Identity, Security and IoT sectors.

With close to €3bn in revenues, IDEMIA is the result of the merger between OT (Oberthur Technologies) and Safran Identity & Security (Morpho). This new company counts 14,000 employees of more than 80 nationalities and serves clients in 180 countries.

| For more information, visit www.idemia.com / Follow @IdemiaGroup on Twitter

© IDEMIA. All rights reserved.

Specifications and information are subject to change without notice.

The products described in this document are subject to continuous development and improvement.

All trademarks and service marks referred to herein, whether registered or not in specific countries, are the properties of their respective owners.

- Printed versions of this document are uncontrolled -

DOCUMENT MANAGEMENT

Business Unit – Department	CI – R&D
Document type	FQR
Document Title	ComblCAO Applet v2.1 in SSCD configuration on Cosmo V9.2 – Public Security Target
FQR No	550 0093
FQR Issue	3

DOCUMENT REVISION

Date	Revision	Modification
2020/03/17	1	Creation of the document
2020/04/13	2	Added Platform version
2020/06/17	3	Updated reference of guidance documents

TABLE OF CONTENTS

1	DEFINITIONS	9
2	REFERENCES.....	10
3	SECURITY TARGET INTRODUCTION	12
3.1	SECURITY TARGET REFERENCE.....	12
3.2	TOE REFERENCE.....	12
3.3	TOE OVERVIEW	12
3.3.1	<i>TOE Type</i>	<i>12</i>
3.3.2	<i>TOE scope.....</i>	<i>13</i>
3.3.3	<i>Required non-TOE hardware/software/firmware</i>	<i>14</i>
3.3.4	<i>Usage and major security features</i>	<i>14</i>
3.4	TOE DESCRIPTION	15
3.4.1	<i>Keys and PINs</i>	<i>16</i>
3.4.2	<i>Access Control Management</i>	<i>16</i>
3.4.3	<i>Authentication of entities.....</i>	<i>16</i>
3.4.4	<i>Digital authentication</i>	<i>16</i>
3.4.5	<i>Electronic Services</i>	<i>17</i>
3.4.6	<i>Secure execution</i>	<i>17</i>
3.5	LIFE CYCLE.....	17
3.5.1	<i>Life cycle overview</i>	<i>17</i>
3.5.2	<i>Development Environment.....</i>	<i>18</i>
3.5.3	<i>Production Environment</i>	<i>19</i>
3.5.4	<i>Preparation Environment</i>	<i>21</i>
3.5.5	<i>Operational Environment</i>	<i>22</i>
4	CONFORMANCE CLAIM	23
4.1	CC AND PACKAGE CONFORMANCE CLAIM	23
4.2	PP CONFORMANCE CLAIM	23
4.3	CONFORMANCE RATIONALE	24
4.3.1	<i>Additional assets.....</i>	<i>24</i>
4.3.2	<i>Additional Roles</i>	<i>24</i>
4.3.3	<i>Additional threats.....</i>	<i>24</i>
4.3.4	<i>Additional OSPs.....</i>	<i>24</i>
4.3.5	<i>Additional objectives</i>	<i>24</i>
4.3.6	<i>Additional SFRs.....</i>	<i>24</i>
4.3.7	<i>Package conformance</i>	<i>24</i>
5	SECURITY PROBLEM DEFINITION	25
5.1	ASSETS.....	25
5.1.1	<i>Assets from Protection Profiles.....</i>	<i>25</i>
5.1.2	<i>Additional Assets.....</i>	<i>25</i>
5.2	USERS / SUBJECTS.....	26
5.2.1	<i>Subjects from Protection Profiles.....</i>	<i>26</i>
5.2.2	<i>Additional Subjects.....</i>	<i>26</i>
5.3	THREATS.....	27
5.3.1	<i>Threats drawn from the Protection Profiles</i>	<i>27</i>
5.3.2	<i>Additional Threats.....</i>	<i>28</i>
5.4	ORGANISATIONAL SECURITY POLICIES	29
5.4.1	<i>Security Policies drawn from the Protection Profiles.....</i>	<i>29</i>
5.4.2	<i>Additional Security Policies.....</i>	<i>30</i>
5.5	ASSUMPTIONS	31

6	SECURITY OBJECTIVES	32
6.1	SECURITY OBJECTIVES FOR THE TOE	32
6.1.1	<i>Security Objectives drawn from the Protection Profiles</i>	<i>32</i>
6.1.2	<i>Additional Security Objectives for the TOE.....</i>	<i>33</i>
6.2	SECURITY OBJECTIVES FOR THE OPERATIONAL ENVIRONMENT	35
6.2.1	<i>Security Objectives drawn from the Protection Profiles</i>	<i>35</i>
6.2.2	<i>Additional Security Objectives for the Operational Environment.....</i>	<i>36</i>
6.3	SECURITY OBJECTIVES RATIONALE.....	37
6.3.1	<i>Threats</i>	<i>37</i>
6.3.2	<i>Organisational Security Policies</i>	<i>40</i>
6.3.3	<i>Assumptions</i>	<i>43</i>
6.3.4	<i>SPD and Security Objectives</i>	<i>43</i>
7	EXTENDED REQUIREMENTS	49
7.1	EXTENDED FAMILIES	49
7.1.1	<i>Extended Family FIA_API - Authentication Proof of Identity</i>	<i>49</i>
7.1.2	<i>Extended Family FPT_EMS - TOE Emanation.....</i>	<i>49</i>
7.1.3	<i>Extended Family FMT_LIM - Limited capabilities and availability.....</i>	<i>50</i>
7.1.4	<i>Extended Family FCS_RND - Generation of random numbers.....</i>	<i>51</i>
8	SECURITY REQUIREMENTS	52
8.1	SECURITY FUNCTIONAL REQUIREMENTS	52
8.1.1	<i>Security Attributes.....</i>	<i>52</i>
8.1.2	<i>SFRs drawn from PP.....</i>	<i>52</i>
8.1.3	<i>Additional SFRs.....</i>	<i>59</i>
8.2	SECURITY ASSURANCE REQUIREMENTS.....	66
8.2.1	<i>ADV Development.....</i>	<i>66</i>
8.2.2	<i>AGD Guidance documents</i>	<i>68</i>
8.2.3	<i>ALC Life-cycle support.....</i>	<i>69</i>
8.2.4	<i>ASE Security Target evaluation</i>	<i>71</i>
8.2.5	<i>ATE Tests.....</i>	<i>73</i>
8.2.6	<i>AVA Vulnerability assessment</i>	<i>74</i>
8.3	SECURITY REQUIREMENTS RATIONALE	75
8.3.1	<i>Objectives</i>	<i>75</i>
8.3.2	<i>Rationale tables of Security Objectives and SFRs.....</i>	<i>81</i>
8.3.3	<i>Dependencies</i>	<i>86</i>
8.3.4	<i>Rationale for the Security Assurance Requirements</i>	<i>92</i>
8.3.5	<i>AVA_VAN.5 Advanced methodical vulnerability analysis</i>	<i>92</i>
8.3.6	<i>ALC_DVS.2 Sufficiency of security measures</i>	<i>92</i>
9	TOE SUMMARY SPECIFICATION	93
9.1	TOE SUMMARY SPECIFICATION.....	93
9.1.1	<i>Description</i>	<i>93</i>
9.2	SFRs AND TSS.....	96
9.2.1	<i>SFRs and TSS - Rationale</i>	<i>96</i>
9.2.2	<i>Association tables of SFRs and TSS</i>	<i>97</i>

TABLE OF FIGURES

Figure 1 - TOE scope	14
Figure 2 - Life Cycle Overview	18

TABLE OF TABLES

Table 1 Roles, actors, sites and coverage for the 3.5.2 development environment	19
Table 2 Image contained both platform and applet is loaded at IC manufacturer (Option 1)	19
Table 3 Cap file of CombICAO Applet v2.1 is loaded through the loader of the IC manufacturer (Option 2)	20
Table 4 Image contained both platform and applet is loaded through the loader of the IC (Option 3)	20
Table 5 Physical delivery of the TOE components from ALC phase to AGD phase	21
Table 6 Threats and Security Objectives - Coverage	44
Table 7 Security Objectives and Threats - Coverage	45
Table 8 OSPs and Security Objectives - Coverage	46
Table 9 Security Objectives and OSPs - Coverage	47
Table 10 Assumptions and Security Objectives for the Operational Environment - Coverage.....	48
Table 11 Security Objectives for the Operational Environment and Assumptions - Coverage.....	48
Table 12 Security Objectives and SFRs - Coverage	83
Table 13 SFRs and Security Objectives	86
Table 14 SFRs Dependencies	91
Table 15 SARs Dependencies	92
Table 16 SFRs and TSS - Coverage.....	99
Table 17 TSS and SFRs - Coverage.....	100

1 Definitions

ADF	Application Dedicated File
AES	Advanced Encryption Standard
AID	Application Identifier
APDU	Application Protocol Data Unit (command received/Data sent by the chip)
API	Application Programming Interfaces
CA	Certification authority
CBC	Cipher Block Chaining
CGA	Certificate Generation Authority (Authority in charge of generating the qualified certificate(s))
C/S	Client / Server
DAP	Data Authentication Pattern
CSP	Certificate Service Provider
DES	Data Encryption Standard
DF	Dedicated File
DH	Diffie Hellman
DTBS	Data to be signed (Sent by the SCA)
DTBS/R Representation	Representation of the Data to be signed
EAL	Evaluation Assurance Level
EF	Elementary File
GP	Global Platform
HID	Human Interface Device
IC	Integrated Chip
MAC	Message Authentication code
PIN	Personal Identification Number
PKI	Public Key Infrastructure
RAD	Reference Authentication Data (PIN stored called also PIN _{sig})
RSA	Rivest Shamir Adleman
SCA	Signature creation Application
SCD	Signature Creation Data
SCP	Secure Channel Procotol
SHA	Secure hashing Algorithm
SSCD	Secure Signature Creation Device
Sub-CA	Subordinate Certificate Authority
SVD	Signature Verification Data
TOE	Target of evaluation
URL	Uniform Resource Locator
USB	Universal Serial Bus
VAD	Verification Authentication Data (PIN submitted by the holder)
XML	eXtensible Markup Language

2 References

[AGD_PRE]	FQR 220 1455 Ed 6 – CombICAO Applet v2.1 – Perso Guide, IDEMIA
[AGD_OPE]	FQR 220 1456 Ed 6– CombICAO Applet v2.1 – User Guide, IDEMIA
[ANSIX9.31]	“Digital Signatures using Reversible Public Key Cryptography for the Financial Services Industry (DSA)” – ANSI X9.31-1998, American Bankers Association
[ANSIX9.62]	ANSI x9.62-2005 Public Key Cryptography for the Financial Services Industry – The Elliptic Curve Digital Signature Algorithm (ECDSA)
[AN10]	JIL – Certification of “open” smart card products – Version 1.1 – 4 February 2013
[CC31-1]	“Common Criteria for information Technology Security Evaluation, Part 1: Introduction and general model”, April 2017, Version 3.1 revision 5
[CC31-2]	“Common Criteria for information Technology Security Evaluation, Part 2: Security Functional requirements”, April 2017, Version 3.1 revision 5
[CC31-3]	“Common Criteria for information Technology Security Evaluation, Part 3: Security Assurance requirements”, April 2017, Version 3.1 revision 5
[Directive]	Directive 1999/93/EC of the European parliament and of the council of 13 December 1999 on a community framework for electronic signatures
[eIDAS]	REGULATION (EU) No 910/2014 OF THE EUROPEAN PARLIAMENT AND OF THE COUNCIL of 23 July 2014 on electronic identification and trust services for electronic transactions in the internal market and repealing Directive 1999/93/EC
[GP2.3]	Global Platform, Card Specification – Version 2.3 – October 2015.
[IEEE]	IEEE Std 1363a-2004 Standard Specification of Public-Key Cryptography
[ISO_15946]	Information technology – Security techniques – Cryptographic techniques based on elliptic curves
[JIL-COMP]	Joint Interpretation Library – Composite product evaluation for Smart Cards and similar devices – v1.2
[PKCS#1]	PKCS #1 v2.1: RSA Cryptography Standard – June 14, 2002
[PKCS#3]	PKCS#3 – Diffie-Hellman Key-Agreement Standard – Version 1.4, November 1, 1993*
[PLT]	ANSSI-CC-2020/08
[PP_IC]	Security IC Platform Protection Profile with augmentation packages – Version 1.0 – BSI-CC-PP-0084-2014
[PTF_AGD1]	ID-One COSMO v9.2 Application Loading Protection Guidance, FQR 110 9292 Ed 1
[PTF_AGD2]	ID-One COSMO v9.2 Applet Security Recommendations, FQR 110 9291 Ed 2
[PTF_AGD3]	ID-One COSMO v9.2 Javadoc, FQR 110 9299 Ed 1

[PTF_AGD4]	JCVM Patch, FQR 110 8805 Ed 2
[PTF_AGD5]	IDEMIA Platform Flash Generation, FQR 110 9402 Ed 1
[PTF_AGD_OPE]	ID-One COSMO v9.2 Reference Guide, FQR 110 9290 Ed 3
[PTF_AGD_PRE]	ID-One COSMO v9.2 Pre-Perso Guide, FQR 110 9289 Ed 3
[PTF_AGD_SEC_A C]	FQR 110 8921 Ed 1 - Secure acceptance and delivery of sensitive elements
[PTF_AGD6]	JBox SW Configuration, FQR 110 9273 Ed 1
[SCP03]	Global Platform Card Technology, Secure Channel Protocol 03, Card Specification v 2.2 - Amendment D - Version 1.1 - September 2009.
[SSCD2]	Protection profiles for secure signature creation device — Part 2: Device with key generation Version 2.0.1 – 23/01/2012 – Reference BSI-CC-PP-0059-2009-MA-01
[SSCD3]	Protection profiles for secure signature creation device — Part 3: Device with key import Version 1.0.2 – 24/07/2012 – Reference BSI-CC-PP-0075
[SSCD4]	Protection profiles for secure signature creation device — Part 4: Extension for device with key generation and trusted communication with certificate generation application Version 1.0.1 – 14/11/12 – Reference BSI-CC-PP-0071
[TR_03110]	TR 03110 v2.10 Advanced Security Mechanisms for Machine Readable Travel Documents, Part 1, Part 2 and Part 3. (2012)
[TR_03111]	Technical Guideline TR-03111 - Elliptic Curve Cryptography - Version 2.0
[CEN_14890]	CEN/EN 14890:2013 Application Interface for smart cards used as Secure Signature Creation
[7816-4]	ISO/IEC 7816-4:2013, Identification Cards — Integrated circuit cards— Part 4 : Organization, security and commands for interchange

3 Security Target Introduction

3.1 Security Target Reference

Title	CombICAO Applet v2.1 in SSCD configuration on Cosmo v9.2 – Public Security Target
Reference and version	FQR 550 0093, version 3
Author	IDEMIA
Certification Body	ANSSI
CC version	3.1 revision 5
EAL	EAL5 augmented with AVA_VAN.5 and ALC_DVS.2
Protection Profiles	PP SSCD-Part 2 Key Generation [SSCD2], PP SSCD-Part 3 Key Import [SSCD3], PP SSCD-Part 4 Key Generation and Trusted Channel with CGA [SSCD4]

3.2 TOE Reference

Product name	CombICAO Applet v2.1
TOE name	CombICAO Applet v2.1 in SSCD configuration on Cosmo v9.2
Developer name	IDEMIA
TOE identification	SAAAAR 203523
Platform reference	IDEMIA ID-ONE Cosmo V9.2 Platform
Platform identification	093772
IC reference	Infineon Security Controller IFX_CCI_000003h, 000005h, 000008h, 00000Ch, 000013h, 000014h, 000015h, 00001Ch, 00001Dh, 000021h, 000022h H13 including the products from the second production line and optional software packages: Flash Loader, Asymmetric Crypto Library, Symmetric Cryptographic Library, Hardware Support Layer, Hash Crypto Library, Mifare Compatible Software, and CIPURSE™ Crypto Library certified by the German BSI certification body (BSI-DSZ-CC-1110-V2-2019) on 18-06-2019)
Guidance documents	[AGD_PRE] and [AGD_OPE] [PTF_AGD_OPE], [PTF_AGD1], [PTF_AGD2], [PTF_AGD3], [PTF_AGD4], [PTF_AGD5], [PTF_AGD6], [PTF_AGD_SEC_AC] and [PTF_AGD_PRE]

The TOE identification is described in [AGD_PRE].

3.3 TOE overview

3.3.1 TOE Type

The CombICAO Applet v2.1 is a configurable applet designed primarily for identification, authentication, signature generation, and as a machine readable travel document (MRTD). This security target focuses only on Qualified Signature Creation Device (QSCD) configuration, used to create advanced or qualified signature in the sense of [eIDAS]. MRTD configurations are managed in others security targets.

The TOE is a composite product made up of an embedded software developed using Java Card technology, composed on a Java Card open platform. Both are developed by IDEMIA.

The Java Card open platform has already been certified. For more details see [PLT].

The embedded software is made up the Java Card CombICAO applet v2.1 [Applet], which relies on Java Card API provided by the underlying Java Card open platform.

3.3.2 TOE scope

The TOE is made up of:

- The underlying Java Card open platform
- The Java Card CombICAO Applet v2.1 code [Applet]
- The associated guidance documentation in [AGD_PRE] and [AGD_OPE];
- The (pre)personalization Agent Key sets.

Moreover, as the [PLT] is certified as a Java Card open platform and complies with the requirements of the Application note 10 [AN10], and as the TOE complies also with [AN10], the TOE may also contain any other applets that comply with [AN10] and the specific requirements of the TOE stated in the guidance documents.

The TOE scope is shown in figure 1. Once constructed, the TOE is a bare microchip with its external interfaces for communication. The physical medium on which the microchip is mounted does not alter nor modify any security functions of the TOE.

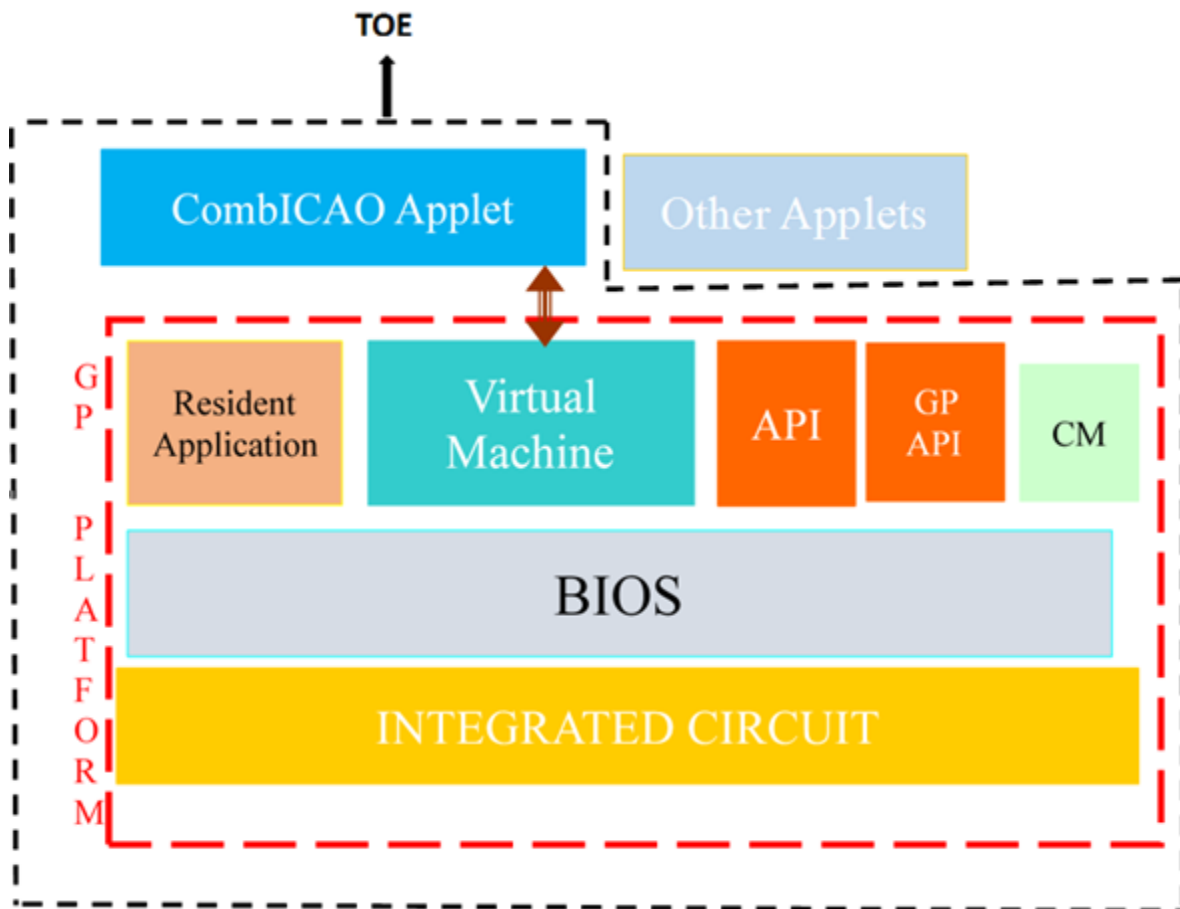

Figure 1 - TOE scope

3.3.3 Required non-TOE hardware/software/firmware

The TOE is a Qualified Signature Creation Device. It is an independent product and does not need any additional hardware/software/firmware to ensure its security.

In order to be powered up and to be able to communicate the TOE needs a reader.

3.3.4 Usage and major security features

The TOE intended usage is to be used as a "qualified signature creation device" with key generation and/or key import, with respect to the [eIDAS].

Within the framework described by [SSCD2], [SSCD3], and [SSCD4], the TOE allows to

- perform basic, advanced and qualified signature;
- authenticate the signatory thanks to PIN verification;
- authenticate one (or several) administrator(s) of the TOE, that may have special rights to administrate the SCD and SVD (generation, import);
- establish trusted channel, protected in integrity, authenticity and confidentiality, with trusted IT entities such as a CGA;
- Secure execution of services.

The scope of [SSCD2], [SSCD3], and [SSCD4] is extended in several ways:

- Personalization phase including:
 - authentication protocol;
 - access control;
 - encryption mechanism involved in key loading;
 - initialization of the data structure;
 - data loading;
 - phase switching.
- All authentication protocols (PACE-GM/IM/CAM) and secure messaging type (DES-128,AES128/192/256);
- All supported digital signature algorithm;
- Authentication of the TOE using asymmetric cryptography;
- All PIN management operations available after delivery point (spanning the three types of PIN : PIN_{Auth}, PIN_{Sig} (called also RAD) & PUK):
 - PIN initialization;
 - Upgrade of PIN attributes;
 - PIN change, unlocking, (re-)initialization;
 - Certificate management.
- PACE authentication;
- Extended Access Control Version 1 as defined in [TR-03110]. It consists of two parts: Chip Authentication Protocol Version 1 and Terminal Authentication Protocol Version 1;
- Signature key import in personalization phase;
- Signature key generation in personalization phase and use phase;
- Signature key public key export in personalization phase and use phase;
- Digital authentication feature including (1) the corresponding key management operation (generation, import), and (2) security policies applicable to each of these operations (authentication, generation, import);

The TOE may be used for various use cases requiring qualified signature:

- Digital signature application;
- Electronic health card;
- Electronic services cards;
-

Depending on the use case and or the ability of the underlying Java Card open platform, the TOE may be used

- in contact mode (T=0 and/or T=1 protocol);
- in contactless protocol (T=CL);

3.4 TOE Description

The TOE is compliant with the specification [CEN_14890], with the following types of data structures:

- files, compliant with [7816-4];
- keys;
- PINs;

The TOE handles the following types of file (described in [7816-4]):

- Transparent File – also named Elementary File (EF);
- Application Dedicated File (ADF);
- Master File (MF);

All these files are organized within a File System compliant to [7816-4]. It represents the hierarchy between all the files. At the top of the structure stands the Master File, it is the default selected file at reset. Under the Master File, are located the Application Dedicated File(s). The Master File, as well as each ADF, may contain Elementary File, keys and/or PINs.

Each file is characterized by its own attributes, such as:

- Access conditions for read and write access (for EF) or selection (for ADF);
- File identifier;
- Location within the File System;
- Size (for EF);

The TOE allows to:

- create two types of file (Application Dedicated File and Elementary File), which updates the File System;
- read, update, resize any Elementary File;
- move within the File Structure by use of file selection;

3.4.1 Keys and PINs

The TOE handles as well cryptographic data objects, such as keys (for digital signature, authentication, and encryption key decipherment) and PINs.

The TOE enables to create, update and use PINs as detailed in [AGD_OPE].

For keys, the TOE enables to create, import, generate and erase keys as detailed in [AGD_OPE].

3.4.2 Access Control Management

The TOE ensures access control on any operations acting on any objects it handles (files, keys or PINs).

Each EF is configured at creation with access conditions protecting read and write access, while the ADF may be configured at creation with access conditions protecting their selection. Keys used for digital authentication, digital signature creation, encryption key decipherment and PINs require specific conditions before they can be used, updated or managed.

Prior to granting access to a given operation, the TOE checks the requested access rights are fulfilled. The access conditions can only be fulfilled upon successful authentication of an entity (see below).

3.4.3 Authentication of entities

The TOE allows authenticating several types of entities in order to grant them some access rights:

- **Authentication of a natural person.** It relies on a successful verification of a PIN code presented to the TOE by the natural person. (only available in phase 7)
- **Authentication of a remote server.** It relies on a mutual authentication - based on PKI - generating a trusted channel ensuring authenticity, integrity and confidentiality of the messages, used to securely communicate. (only available in phase 7)
- **Authentication of personalization agent** (only in phase 6);

These authentication mechanisms allows fulfilling the access control mechanisms described above.

3.4.4 Digital authentication

The TOE supports digital authentication based on RSA and elliptic curves cryptography (ECC). Digital authentication is the process by which (1) the holder of TOE authenticates itself to the TOE using a PIN, releasing access right to an authentication key stored in the TOE, (2) subsequently the authentication key is used by the TOE to authenticate itself on behalf of the TOE holder. Digital authentication is useful so that the TOE holder can authenticate himself on line, without compromising any sensitive assets (PINs or authentication key).

3.4.5 Electronic Services

The TOE supports as well several electronic services:

- **Digital signature:** this feature enables the signatory to electronically signs documents. The signature may be either advanced or qualified (compliant with [SSCD2] and [SSCD3]).
- **Encryption key decipherment:** this feature enables the document holder to store secret data on an electronic vault. The key needed to decipher the key encrypting these data is securely stored in the TOE. The document holder's computer sends the encrypted encryption key to the TOE to get the plain encryption key.

3.4.6 Secure execution

The TOE ensures a secure execution of its services. First, the TOE ensures its execution is protected against physical manipulation or attempt to tamper with. Secondly, should the execution of the TOE be tampered with in any manner, the TOE ensures it remains in a safe state protecting its assets and the TSFs, so that no vulnerabilities can be exploited by an attacker.

3.5 Life Cycle

3.5.1 Life cycle overview

The TOE life cycle in the figure 2 distinguishes stages for development, production, preparation and operational use in accordance with the standard smart card life cycle [PP_IC].

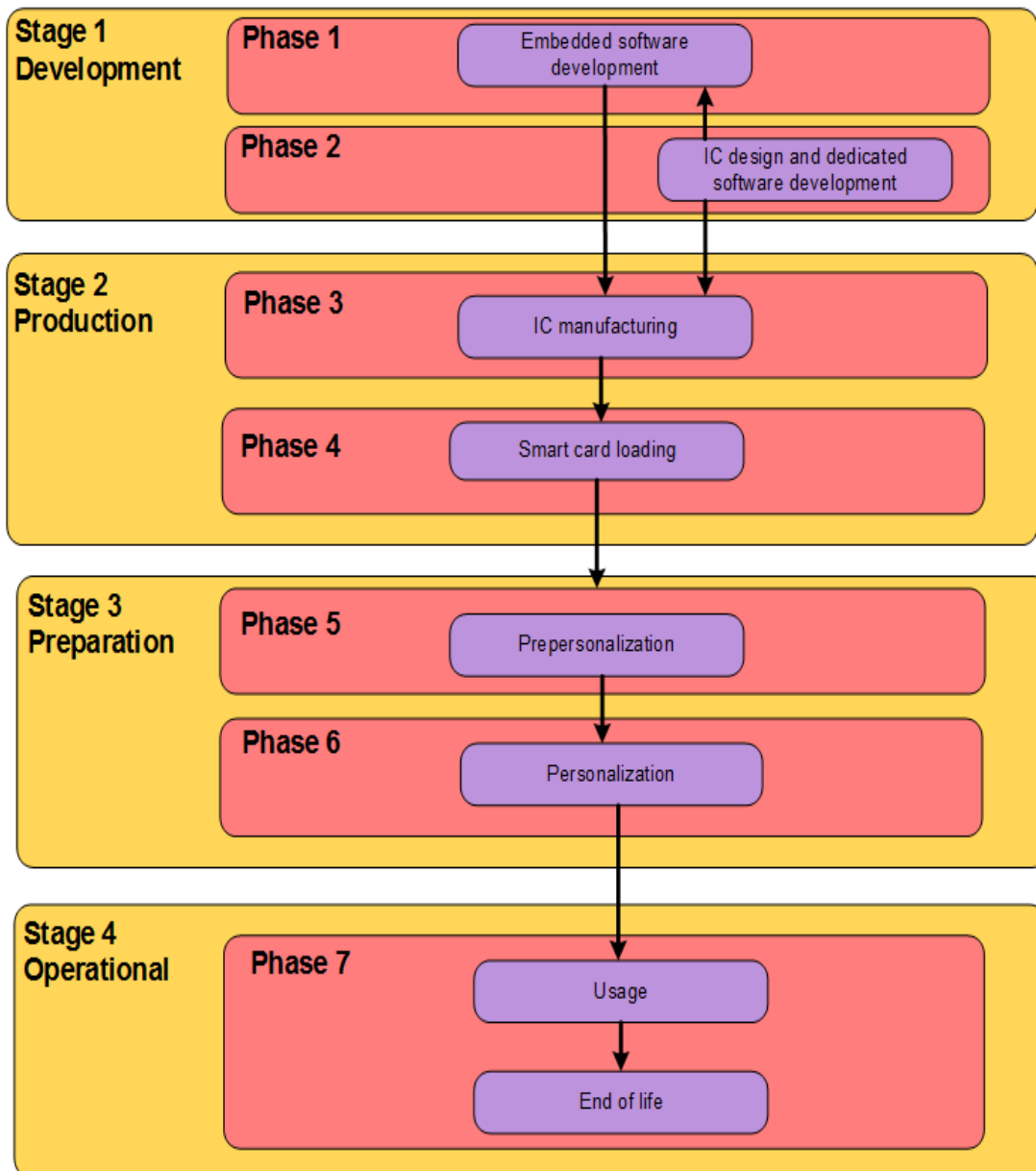

Figure 2 - Life Cycle Overview

3.5.2 Development Environment

In this environment, the following two phases take place:

- Phase 1: IC Embedded Software Development (Java Card Open Platform components and CombICAO Applet v2.1)
- Phase 2: IC Development

The IC Embedded Software Developer is in charge of the specification, development and validation of the software (Java Card Open Platform and CombICAO Applet v2.1).

The IC Developer designs the IC, develops the IC dedicated software and provides information, software or tools to the IC embedded software developer.

Roles, actors, sites and coverage for this environment of the product life-cycle are listed in the table below:

Role	Actor	Site	Covered by
CombICAO Applet v2.1 Developer	IDEMIA	IDEMIA R&D sites	ALC
Redaction and Review of Documents	IDEMIA	IDEMIA R&D site	ALC
Platform Developer	IDEMIA	IDEMIA R&D sites Refer to [PLT]	ALC
IC Developer	Infineon	Infineon R&D sites Refer to [PLT]	ALC

Table 1 Roles, actors, sites and coverage for the 3.5.2 development environment

3.5.3 Production Environment

In this environment, the following two phases take place:

- Phase 3: IC manufacturing
- Phase 4: Smart card loading

The IC manufacturer is responsible for producing the IC (manufacturing, testing, initialization). Depending on the intention:

- **(Option 1)** the developer sends the image (containing both the Java Card platform and the CombICAO Applet v2.1) to be flashed in the IC to the IC manufacturer in the phase 3.

Or

- **(Option 2)** the platform developer sends the image (containing only the Java Card platform) to be flashed in the IC to the IC manufacturer in the phase 3. Once the Java Card platform has been loaded, the package of CombICAO v2.1 is securely delivered from the applet developer to the smart card loader. The cap file of the applet is then loaded (using GP) in the Java Card platform by the smart card loader in phase 4 at IDEMIA audited site.

Or

- **(Option 3)** the developer sends the image (containing both the Java Card platform and the CombICAO Applet v2.1) to be loaded in Flash (using the loader of the IC) to the smart card loader in phase 4.

Several life cycles are available, depending when the Flash Code is loaded. The following tables present roles, actors, sites and coverage for this for this environment of the product life-cycle and describe for each of them the TOE delivery point.

Role	Package to be loaded	Actor	Site	Covered by
IC manufacturer	Image containing both Java Card platform and applet	IC manufacturer	IC manufacturer production plants Refer to [PLT]	ALC
Smart card loader	-	-	-	-
TOE Delivery Point				

Table 2 Image contained both platform and applet is loaded at IC manufacturer (Option 1)

Role	Package to be loaded	Actor	Site	Covered by
IC manufacturer	Image containing only Java Card platform	IC manufacturer	IC manufacturer production plants Refer to [PLT]	ALC
Smart card loader	Cap file of the applet	IDEMIA	IDEMIA plants	ALC
TOE Delivery Point				

Table 3 Cap file of CombiCAO Applet v2.1 is loaded through the loader of the IC manufacturer (Option 2)

Role	Package to be loaded	Actor	Site	Covered by
IC manufacturer	-	-	-	-
TOE Delivery Point				
Smart card loader	Image containing both Java Card platform and applet	IDEMIA or another agent	IDEMIA plants or others sites	AGD

Table 4 Image contained both platform and applet is loaded through the loader of the IC (Option 3)

The following table describes the physical delivery of the TOE components from ALC phase to AGD phase:

TOE component	Identification	Package	Delivery method
CombICAO Applet v2.1 in SSCD configuration on Cosmo v9.2	SAAAAR 203523	The package can be either of the following: <ul style="list-style-type: none"> - Image contained both platform and applet, - Chip embedded in ID1 cards or ID3 holder pages, - Chip embedded in antenna inlays, - Chip in modules. 	CPS tool is used in the case of an Image delivery. Otherwise, trusted courier is used.
[AGD_PRE]	FQR 220 1455	Electronic document	PGP-encrypted email
[AGD_OPE]	FQR 220 1456	Electronic document	PGP-encrypted email
[PTF_AGD1]	FQR 110 9292	Electronic document	PGP-encrypted email
[PTF_AGD2]	FQR 110 9291	Electronic document	PGP-encrypted email
[PTF_AGD3]	FQR 110 9929	Electronic document	PGP-encrypted email
[PTF_AGD4]	FQR 110 9402	Electronic document	PGP-encrypted email
[PTF_AGD5]	FQR 110 8805	Electronic document	PGP-encrypted email
[PTF_AGD6]	FQR 110 9273	Electronic document	PGP-encrypted email
[PTF_AGD_OPE]	FQR 110 9290	Electronic document	PGP-encrypted email
[PTF_AGD_PRE]	FQR 110 9289	Electronic document	PGP-encrypted email
[PTF_AGD_SEC_AC]	FQR 110 8921	Electronic document	PGP-encrypted email
(Pre)Personalization Agent Key set	n.a	Electronic file	PGP encrypted parts on USB or CD media, off-line registered distribution by trusted courier.

Table 5 Physical delivery of the TOE components from ALC phase to AGD phase

3.5.4 Preparation Environment

In this environment, the following two phases take place:

- Phase 5: Pre-personalization
- Phase 6: Personalization

The preparation environment may not necessarily take place in a manufacturing site, but may be performed anywhere. All along these two phases, the TOE is self-protected as it requires the authentication of the pre-personalization agent or personalization agent prior to any operation. The CombICAO Applet v2.1 is pre-personalized and personalized according to [AGD_PRE].

At the end of phase 6, the TOE is constructed. These two phases are covered by [AGD_PRE] tasks of the TOE and AGD_OPE tasks of [PLT]. Notice that all security features related to the pre-personalization phase are covered by the underlying platform [PLT].

3.5.5 Operational Environment

The TOE is under the control of the User (Signatory and/or Administrator).

During this phase, the TOE may be used as described in §3.4. This phase is covered by [AGD_OPE] tasks of the TOE and AGD_OPE tasks of [PLT].

4 Conformance Claim

4.1 CC and package Conformance claim

This security target claims conformance to the Common Criteria version 3.1, revision 5 ([CC31-1], [CC31-2] and [CC31-3]).

The conformance to the Common Criteria is claimed as follows:

CC	Conformance rationale
Part 1	Strict Conformance
Part 2	Conformance extended with <ul style="list-style-type: none"> ▪ FCS.RND.1: “Quality Metric for Random Numbers” ▪ FPT_EMS.1: “TOE Emanation” ▪ FIA_API.1: “Authentication proof of Identity” ▪ FMT_LIM.1 Limited capabilities ▪ FMT_LIM.2 Limited availability
Part 3	Conformance to assurance package EAL 5, augmented with <ul style="list-style-type: none"> ▪ AVA_VAN.5: “Advanced methodical vulnerability analysis” ▪ ALC_DVS.2: “Sufficiency of security measures”

Moreover the security target claims compliance with application note 10 [AN10].

4.2 PP Conformance Claim

This security target claims a **strict** conformance to the Secure Signature Creation Device (SSCD) Protection Profile [SSCD2], [SSCD3] conform to CC version 3.1 revision 3 and [SSCD4] conform to CC version 3.1 revision 4.

This ST also addresses the manufacturing and personalization phases at TOE level (cf. TOE life cycle presented in §3.5). These additions do not contradict any of the threats, assumptions, organizational policies, objectives or SFRs stated in the protection profiles that cover the operational phase of the signature device.

This ST also addresses Extended Access Control. The additional functionality of the Extended Access Control protocol available in operational use phase has been added to the TOE with:

- additional assets
- additional roles
- additional threats
- additional OSPs
- additional objectives for the TOE
- additional objectives for the environment
- additional SFRs

All these additions are inspired from the [PP-EAC2]. Notice that the added security objectives for the operational environment do not mitigate any threats of [SSCD2], [SSCD3], [SSCD4] and don't fulfil any OSPs meant to be addressed by security objectives for the TOE in [SSCD2], [SSCD3], [SSCD4].

Additional information is stated in the following chapter.

4.3 Conformance Rationale

4.3.1 *Additional assets*

All assets from the protection profiles are included in this security target. Other assets have been added (see section 5.1.2).

4.3.2 *Additional Roles*

The roles from protection profiles are maintained in this security target. Other roles have been added (see section 5.2.2).

4.3.3 *Additional threats*

All the threats from the protection profiles are maintained in this security target. Other threats have been added (see section 5.3.2).

4.3.4 *Additional OSPs*

All the Policies from the protection profiles are maintained in this security target. Other OSPs have been added (see section 5.4.2).

4.3.5 *Additional objectives*

4.3.5.1 *Additional Security objectives for the TOE*

All the security objectives for the TOE from the protection profiles are maintained in this security target. Other security objectives for the TOE have been added (see section 6.1.2).

4.3.5.2 *Additional Security objectives for the Operational Environment*

All the security objectives for the operational environment from the protection profiles are maintained in this security target. Other security objectives for the operational environment have been added (see section 6.2.2).

4.3.6 *Additional SFRs*

All the SFRs from the protection profiles are maintained. Other SFRs have been added (see section 8.1.3).to cover supplemental features.

4.3.7 *Package conformance*

The protection profiles require an assurance level of level EAL4 augmented with AVA_VAN.5. This security target considers an assurance level EAL5 augmented with AVA_VAN.5 and ALC_DVS.2, which still complies with the requirements of the protection profiles.

5 Security Problem Definition

5.1 Assets

5.1.1 Assets from Protection Profiles

SCD

Signature Creation Data

Private key used to perform an electronic signature operation. The confidentiality, integrity and signatory's sole control over the use of the SCD must be maintained.

SVD

Signature Verification Data

Public key linked to the SCD and used to perform electronic signature verification. The integrity of the SVD when it is exported must be maintained.

DTBS/R

Data to be signed or its unique Representation

Set of data, or its representation, which the signatory intends to sign. Their integrity and the unforgeability of the link to the signatory provided by the electronic signature must be maintained.

5.1.2 Additional Assets

Keys

Private or secret key(s) used to (1) authenticate an external user or entity, (2) perform authentication protocols, (3) perform digital authentication, (4) perform digital signature or (5) perform encryption key decipherment. Their integrity and confidentiality must be maintained.

Public key(s) used as trust anchor to verify a certificate chain used in terminal authentication. Their integrity must be maintained.

PIN/PUK

The applet shall manage two types of PINs (PINSig called also RAD and PINAuth) for user authentication and one PUK for management purpose. They are used to authenticate natural persons. The PINs and PUK must be created and initialized first before they can be used for authentication.

VAD

PIN code entered by the end user to perform a signature operation (confidentiality and authenticity of the VAD as needed by the authentication method employed)

Session Keys

Keys computed for secure messaging and used to ensure confidentiality, authenticity and integrity of data.

Authenticity of the Electronic Documents Chip

The authenticity of the electronic document's chip, personalized by the issuing organization for the Document holder, is used by the electronic document presenter to prove his possession of a genuine electronic document.

Tracing Data

Technical information about the current and previous locations of the electronic document gathered unnoticeable by the Document holder recognizing the TOE not knowing any PACE password. TOE tracing data can be provided / gathered.

Sensitive User Data

User data, which have been classified as sensitive data by the electronic document issuer. Sensitive user data are a subset of all user data, and are protected by EAC.

User Data stored on the TOE

All data, with the exception of authentication data, that are stored in the context of the application(s) on the electronic document. These data are allowed to be accessed either by a BAT, or, in the case of sensitive data, by an Authentication Terminal with appropriate authorization level.

User Data transferred between the TOE and the Terminal

All data, with the exception of authentication data, that are transferred (both directions) during usage of the application(s) of the electronic document between the TOE and authenticated terminals.

Accessibility of TOE Functions and Data only for Authorized Subjects

Property of the TOE to restrict access to TSF and TSF-Data stored in the TOE to authorized subjects only.

Genuineness of the TOE

Property of the TOE to be authentic in order to provide claimed security functionality in a proper way.

Electronic Document Communication Establishment Authorization Data

Restricted-revealable authorization information for a human user used for verification of the authorization attempts as an authorized user (PACE password). These data are stored in the TOE and not send to it. Restricted-revealable here refers to the fact that if necessary, the Document holder may reveal her verification values of CAN to an authorized person, or to a device that acts according to respective regulations and is considered trustworthy.

Secret Document Holder Authentication Data

Secret authentication information for the Document holder being used for verification of the authentication attempts as authorized Document holder (sent PACE passwords, e.g. PIN, PUK or CAN).

TOE internal Non-Secret Cryptographic Material

Permanently or temporarily stored non-secret cryptographic (public) keys and other non-secret material used by the TOE in order to enforce its security functionality.

5.2 Users / Subjects

5.2.1 Subjects from Protection Profiles

User

End user of the TOE who can be identified as administrator or signatory. The subject S.User may act as S.Admin in the role R.Admin or as S.Sigy in the role R.Sigy.

Administrator

User who is in charge to perform the TOE initialisation, TOE (pre-)personalisation or other TOE administrative functions. The subject S.Admin is acting in the role R.Admin for this user after successful authentication as administrator.

Application Note:

For all activities related to Personalization, the subject Administrator is also called Personalization Agent in the rest of the document

Signatory

User who hold the TOE and use it on their own behalf or on behalf of the natural or legal person or entity they represent. The subject S.Sigy is acting in the role R.Sigy for this user after successful authentication as signatory.

Attacker

Human or process acting on their behalf located outside the TOE. The main goal of the attacker is to access the SCD or to falsify the electronic signature. The attacker has got a high attack potential and knows no secret.

5.2.2 Additional Subjects

Issuer Certification Authority (Issuer CA)

An organization enforcing the policy of the electronic document issuer, i. e. confirming correctness of user and TSF data that are stored within the electronic document. The Issuer CA represents both the (1) root and (2) intermediate sub-CAs of the public key infrastructure (PKI) used to issue the electronic document. The Issuer CA signs user and TSF data to create a digital seals that is stored in the electronic document to demonstrate their integrity and authenticity.

Country Verifying Certification Authority (CVCA)

The Country Verifying Certification Authority (CVCA) enforces the privacy policy of the issuing state or organization, i. e. enforcing protection of sensitive user data that are stored in the electronic document. The CVCA represents the country specific root of the PKI of Authentication Terminals and

eServices certification authorities, and creates eServices certification authorities certificates within this PKI. Updates of the public key of the CVCA are distributed as CVCA Link-Certificates, see [TR-03110].

eService Certification Authority

An organization issuing terminal certificates. The eService certification authority is a certificate authority, authorized by the corresponding CVCA to issue certificates for Authentication Terminals.

Document Holder

A person who the electronic document issuer has personalized the electronic document for. Personalization here refers to associating a person uniquely with a specific electronic document. Note that an Document holder can also be an attacker. The document holder is equivalent to the signatory and can use and manage the PINSig (called also the RAD), the PINAuth and the PUK.

Electronic Document Presenter

A person presenting the electronic document to a terminal and claiming the identity of the Document holder. Note that an electronic document presenter can also be an attacker.

Basic Authentication Terminal (BAT)

A BAT implements the terminal part of the PACE protocol and/or the VERIFY PIN command and authenticates itself to the electronic document using a shared password (CAN, PIN, PUK). A BAT is not allowed to access sensitive user data.

Authentication Terminal

A terminal that has successfully passed Terminal Authentication is an Authentication Terminal. It is authorized by the electronic document issuer through the eServices certification authorities of the receiving branch (by issuing terminal certificates) to access a subset or all of the data stored on the electronic document.

Terminal

A terminal is any technical system communicating with the TOE through the contactless or contact-based interface. The role terminal is the default role for any terminal being recognized by the TOE that is neither a BAT nor an Authentication Terminal.

5.3 Threats

5.3.1 Threats drawn from the Protection Profiles

T.SCD_Divulg

Storing, copying and releasing of the signature creation data

An attacker stores or copies the SCD outside the TOE. An attacker can obtain the SCD during generation, storage and use for signature creation in the TOE.

T.SCD_Derive

Derive the signature creation data

An attacker derives the SCD from publicly known data, such as SVD corresponding to the SCD or signatures created by means of the SCD or any other data exported outside the TOE, which is a threat against the secrecy of the SCD.

T.Hack_Phys

Physical attacks through the TOE interfaces

An attacker interacts physically with the TOE to exploit vulnerabilities, resulting in arbitrary security compromises. This threat is directed against SCD, SVD and DTBS.

T.SVD_Forgery

Forgery of the signature verification data

An attacker forges the SVD presented by the CSP to the CGA. This results in loss of SVD integrity in the certificate of the signatory.

T.SigF_Misuse

Misuse of the signature creation function of the TOE

An attacker misuses the signature creation function of the TOE to create a digital signature for data the signatory has not decided to sign. The TOE is subject to deliberate attacks by experts possessing a high attack potential with advanced knowledge of security principles and concepts employed by the TOE.

T.DTBS_Forgery

Forgery of the DTBS/R

An attacker modifies the DTBS/R sent by the SCA. Thus the DTBS/R used by the TOE for signing does not match the DTBS the signatory intended to sign.

T.Sig_Forgery***Forgery of the electronic signature***

An attacker forges a signed data object, maybe using an electronic signature which has been created by the TOE, and the violation of the integrity of the signed data object is not detectable by the signatory or by third parties. The signature created by the TOE is subject to deliberate attacks by experts possessing a high attack potential with advanced knowledge of security principles and concepts employed by the TOE.

5.3.2 Additional Threats**T.Key_Divulg*****Storing, copying, and releasing of a key stored in the TOE***

An attacker can store and copy a key (other than SCD) stored in the TOE outside the TOE. An attacker can release a key during generation, storage and use in the TOE.

T.Key_Derive***Derive a key***

An attacker derives a key (other than SCD) from public known data, such as the corresponding public key or cryptogram created by means of the key or any other data communicated outside the TOE, which is a threat against the secrecy of the key.

T.TOE_PublicAuthKey_Forgery***Forgery of the public key of a TOE authentication key***

An attacker forges the public key of a TOE authentication key presented by the TOE. This results in loss of the public key integrity in the authentication certificate of the TOE.

T.Authentication_Replay***Replay of an authentication of an external entity***

An attacker retrieves by observation authentication data used by a third party during an authentication sequence. The attacker tries to replay this authentication sequence to grant access to the TOE.

T.Counterfeit

An attacker with high attack potential produces an unauthorized copy or reproduction of a chip of a genuine electronic document. This copy or reproduction can be used as a part of a counterfeit electronic document. This violates the authenticity of the electronic document's chip used for authentication of an electronic document presenter by possession of an electronic document. The attacker may generate a new data set or extract completely or partially the data from a genuine electronic document's chip and copy them to another appropriate chip to imitate the chip of the genuine electronic document.

Threat agent: having high attack potential, being in possession of one or more legitimate ID-Cards

T.Sensitive_Data

An attacker tries to gain access to sensitive user data through the communication interface (contact or contactless) of the electronic document's chip. The attack T.Sensitive_Data is similar to the threat T.Skimming from [PACEPP] w.r.t. the attack path (communication interface) and the motivation (to get data stored on the electronic document's chip) but differs from those in the asset under the attack, the opportunity (i.e. knowing the PACE Password or the PIN) and therefore the possible attack methods.

Threat agent: having high attack potential, knowing the PACE Password or the PIN, being in possession of a legitimate electronic document

T.Abuse-Func

An attacker may use functions of the TOE which shall not be used in TOE operational phase in order (i) to manipulate or to disclose the User Data stored in the TOE, (ii) to manipulate or to disclose the TSF-data stored in the TOE or (iii) to manipulate (bypass, deactivate or modify) soft-coded security functionality of the TOE. This threat addresses the misuse of the functions for the initialization and Personalization in the operational phase after delivery to the holder.

T.Eavesdropping

An attacker is listening to the contactless communication between the electronic document and the BAT in order to gain the user data transferred between the TOE and the terminal connected.

T.Forgery

An attacker fraudulently alters the User Data or/and TSF-data stored on the electronic document or/and exchanged between the TOE and the terminal connected in order to outsmart the BAT by means of changed electronic document holder's related reference data. The attacker does it in such a way that the terminal connected perceives these modified data as authentic one.

T.Information_Leakage

An attacker may exploit information leaking from the TOE during its usage in order to disclose confidential User Data or/and TSF-data stored on the electronic document or/and exchanged between the TOE and the terminal connected. The information leakage may be inherent in the normal operation or caused by the attacker.

T.Malfunction

An attacker may cause a malfunction the electronic document's hardware and Embedded Software by applying environmental stress in order to (i) deactivate or modify security features or functionality of the TOE' hardware or to (ii) circumvent, deactivate or modify security functions of the TOE's Embedded Software. This may be achieved e.g. by operating the electronic document outside the normal operating conditions, exploiting errors in the electronic document's Embedded Software or misusing administrative functions. To exploit these vulnerabilities an attacker needs information about the functional operation.

T.Phys-Tamper

An attacker may perform physical probing of the electronic document in order (i) to disclose the TSF-data, or (ii) to disclose/reconstruct the TOE's Embedded Software. An attacker may physically modify the electronic document in order to alter (i) its security functionality (hardware and software part, as well), (ii) the User Data or the TSF-data stored on the travel document.

T.Skimming

An attacker imitates a terminal in order to get access to the user data stored on or transferred between the TOE and the inspecting authority connected via the contactless interface of the TOE.

T.Tracing

An attacker tries to gather TOE tracing data (i.e. to trace the movement of the electronic document) unambiguously identifying it remotely by establishing or listening to a communication via the contactless interface of the TOE.

5.4 Organisational Security Policies

5.4.1 Security Policies drawn from the Protection Profiles

P.CSP_QCert

Qualified certificate

The CSP uses a trustworthy CGA to generate a qualified certificate or non-qualified certificate (cf. [directive], article 2, clause 9, and Annex I) for the SVD generated by the SSCD. The certificates contain at least the name of the signatory and the SVD matching the SCD implemented in the TOE under sole control of the signatory. The CSP ensures that the use of the TOE as SSCD is evident with signatures through the certificate or other publicly available information.

P.QSign

Qualified electronic signatures

The signatory uses a signature creation system to sign data with an advanced electronic signature (cf. the directive, article 1, clause 2), which is a qualified electronic signature if it is based on a valid qualified certificate (according to the directive Annex I [DIR]). The DTBS are presented to the signatory and sent by the SCA as DTBS/R to the SSCD. The SSCD creates the electronic signature created with a SCD implemented in the SSCD that the signatory maintain under their sole control and is linked to the DTBS/R in such a manner that any subsequent change of the data is detectable.

P.Sigy_SSCD

TOE as secure signature creation device

The TOE meets the requirements for an SSCD laid down in Annex III of the directive [DIR]. This implies the SCD is used for digital signature creation under sole control of the signatory and the SCD can practically occur only once.

P.Sig_Non-Repud

Non-repudiation of signatures

The lifecycle of the SSCD, the SCD and the SVD shall be implemented in a way that the signatory is not able to deny having signed data if the signature is successfully verified with the SVD contained in their unrevoked certificate.

5.4.2 Additional Security Policies

P.LinkSCD_QualifiedCertificate

Link between a SCD stored in the TOE and the relevant qualified certificate

The Role in charge of creating and updating the SCD (Personalization Agent, R.Admin), or the trusted IT entity involved in the updating process (CSP) shall ensure an unambiguous link between the (qualified) certificate(s) and the corresponding SCD(s). This link might be figured out by a PKCS#15 structure, an XML structure, an identifier linking the file containing the (qualified) certificate or the URL hosting them to the SCD(s) stored in the TOE. In particular, it implies this link is updated, each time the SCD(s) is created, imported, erased or generated.

P.TOE_PublicAuthKey_Cert

Certificate for asymmetric TOE authentication keys

The TOE contains certificate(s) issued by a known entity ensuring its public key corresponding to the authentication private key is genuine.

P.eServices

Provision of eServices

The TOE provides the following mechanisms:

decrypt encryption decipherment keys using asymmetric mechanisms;

digital authentication: authentication of the TOE (on behalf of the TOE holder) using an asymmetric private key;

Moreover, the TOE ensures these keys remain genuine by enforcing an access control over the update of these keys, in order to ensure that only entitled entities can change them.

P.EAC_Terminal

Terminals that intent to be Authentication Terminals must implement the respective terminal part of the protocols required to execute EAC protocol, and store (static keys) or generate (temporary keys and nonces) the corresponding credentials.

P.Terminal_PKI

The electronic document issuer shall establish a public key infrastructure for the card verifiable certificates used for Terminal Authentication. For this aim, the electronic document issuer shall run a Country Verifying Certification Authority. The instances of the PKI shall fulfill the requirements and rules of the corresponding certificate policy. The electronic document issuer shall make the CVCA certificate available to the personalization agent or the manufacturer.

P.Card_PKI

The description below states the responsibilities of involved parties and represents the logical, but not the physical structure of the PKI. Physical distribution ways shall be implemented by the involved parties in such a way that all certificates belonging to the PKI are securely distributed / made available to their final destination, e.g. by using directory services.

The electronic document Issuer shall establish a public key infrastructure to ensure the integrity and authenticity of the content of the electronic document, through the generation of digital seals protecting the data it contains. For this aim, it runs an Issuer CA.

The Issuer CA shall securely generate, store and use the Issuer CA key pair. The Issuer CA shall keep the Issuer CA Private Key secret.

P.Pre-Operational

The electronic document Issuer issues the electronic document and approves it using the terminals complying with all applicable laws and regulations.

The electronic I document Issuer guarantees correctness of the user data (amongst other of those, concerning the travel document holder) and of the TSF-data permanently stored in the TOE.

The electronic document Issuer uses only such TOE's technical components (IC) which enable traceability of the electronic documents in their manufacturing and issuing life cycle phases, i.e. before they are in the operational phase,

If the electronic document Issuer authorizes a Personalization Agent to personalize the electronic document for electronic document holders, the electronic document Issuer has to ensure that the Personalization Agent acts in accordance with the electronic document Issuer's policy.

P.Terminal

The BAT shall operate their terminals as follows:

The related terminals shall be used by terminal operators and by electronic document holders.

They shall implement the terminal parts of the PACE protocol and check the digital seal generated by the Issuer CA included in the electronic document and protecting its content. The BAT shall use randomly and (almost) uniformly selected nonces, if required by the protocols (for generating ephemeral keys for Diffie-Hellmann).

They shall also securely store the Issuer CA certificate in order to be able to verify the digital seals generated by the Issuer CA and included in the electronic document to protect its content (integrity and authenticity of the data stored in the electronic document).

The related terminals and their environment shall ensure confidentiality and integrity of respective data handled by them (e.g. confidentiality of PACE passwords or the PIN, integrity of PKI certificates, etc.).

P.Trustworthy_PKI

The Issuer CA shall ensure that it issues its certificates exclusively to the rightful organizations and that they create exclusively correct digital seals to be stored on the electronic document.

5.5 Assumptions

A.CGA

Trustworthy certificate generation application

The CGA protects the authenticity of the signatory's name or pseudonym and the SVD in the (qualified) certificate by an advanced electronic signature of the CSP.

A.SCA

Trustworthy signature creation application

The signatory uses only a trustworthy SCA. The SCA generates and sends the DTBS/R of data the signatory wishes to sign in a form appropriate for signing by the TOE.

A.CSP

Secure SCD/SVD management by CSP

The CSP uses only a trustworthy SCD/SVD generation device and ensures that this device can be used by authorised user only. The CSP ensures that the SCD generated practically occurs only once, that generated SCD and SVD actually correspond to each other and that SCD cannot be derived from the SVD. The CSP ensures the confidentiality of the SCD during generation and export to the TOE, does not use the SCD for creation of any signature and irreversibly deletes the SCD in the operational environment after export to the TOE.

6 Security Objectives

6.1 Security Objectives for the TOE

6.1.1 Security Objectives drawn from the Protection Profiles

OT.Lifecycle_Security

Lifecycle security

The TOE shall detect flaws during the initialisation, personalisation and operational usage. The TOE shall securely destroy the SCD on demand of the signatory.

OT.SCD/SVD_Auth_Gen

Authorized SCD/SVD generation

The TOE shall provide security features to ensure that authorised users only may invoke the generation of the SCD and the SVD.

OT.SCD_Unique

Uniqueness of the signature creation data

The TOE shall ensure the cryptographic quality of an SCD/SVD pair it creates as suitable for the advanced or qualified electronic signature. The SCD used for signature creation shall practically occur only once and shall not be reconstructable from the SVD. In that context 'practically occur once' means that the probability of equal SCDs is negligible.

OT.SCD_SVD_Corresp

Correspondence between SVD and SCD

The TOE shall ensure the correspondence between the SVD and the SCD generated by the TOE. This includes unambiguous reference of a created SVD/SCD pair for export of the SVD and in creating an electronic signature creation with the SCD.

OT.SCD_Auth_Imp

Authorized SCD import

The TOE shall provide security features to ensure that authorised users only may invoke the import of the SCD.

OT.SCD_Secrecy

Secrecy of the signature creation data

The secrecy of the SCD (used for signature creation) shall be reasonably assured against attacks with a high attack potential.

OT.Sig_Secure

Cryptographic security of the electronic signature

The TOE shall create digital signatures that cannot be forged without knowledge of the SCD through robust encryption techniques. The SCD shall not be reconstructable using the digital signatures or any other data exportable from the TOE. The digital signatures shall be resistant against these attacks, even when executed with a high attack potential.

OT.Sigy_SigF

Signature creation function for the legitimate signatory only

The TOE shall provide the digital signature creation function for the legitimate signatory only and protects the SCD against the use of others. The TOE shall resist attacks with high attack potential.

OT.DTBS_Integrity_TOE

DTBS/R integrity inside the TOE

The TOE must not alter the DTBS/R. As by definition of the DTBS/R this may consist of the DTBS themselves, this objective does not conflict with a signature creation process where the TOE hashes the provided DTBS (in part or entirely) for signature creation.

OT.EMSEC_Design

Provide physical emanations security

The TOE shall be designed and built in such a way as to control the production of intelligible emanations within specified limits.

OT.Tamper_ID

Tamper detection

The TOE shall provide system features that detect physical tampering of its components, and uses those features to limit security breaches.

OT.Tamper_Resistance***Tamper resistance***

The TOE shall prevent or resist physical tampering with specified system devices and components.

OT.TOE_SSCD_Auth***Authentication proof as SSCD***

The TOE shall hold unique identity and authentication data as SSCD and provide security mechanisms to identify and to authenticate itself as SSCD.

OT.TOE_TC_SVD_Exp***TOE trusted channel for SVD export***

The TOE shall provide a trusted channel to the CGA to protect the integrity of the SVD exported to the CGA. The TOE shall enable the CGA to detect alteration of the SVD exported by the TOE.

6.1.2 Additional Security Objectives for the TOE**OT.Authentication_Secure*****Secure authentication mechanisms***

The natural person can authenticate itself to the TOE via the PACE protocol and/or the VERIFY PIN command. Notice that The usage of PACE protocol is mandatory only for contactless mode. The TOE provides (1) strong mechanism to authenticate external user/entity, and (2) strong mechanisms to authenticate the TOE.

Mechanisms to perform mutual authentication

These mechanisms aim at (1) authenticating the TOE to the outside entity, and (2) authenticating the outside entity to the TOE. In phase 7, the mechanisms rely on asymmetric cryptography, while before phase 7 they rely on symmetric cryptography. In the course of the mutual authentication, the TOE authenticates the outside entity using a freshly generated random number in order to avoid replay attacks. Moreover, these mechanisms also generate trusted channel ensuring integrity, authenticity, and confidentiality of the communication using strong encryption techniques. It also ensures protection against deletion, and modification of commands. Moreover, the TOE ensures the key its uses are genuine by enforcing an access control over the authentication keys update, in order to ensure that only entitled entities can change key values. These mechanisms provided by the electronic document's chip are protected against attacks with high attack potential.

Mechanisms to authenticate the TOE

These mechanisms rely on asymmetric cryptography and ensure that (1) the cryptogram can not be forged without the knowledge of the authentication key, and (2) they can not be reconstructed from the authentication cryptograms.

Moreover the TOE ensures the key its uses are genuine by enforcing an access control over the authentication keys update, in order to ensure that only entitled entities can change key values.

These mechanisms provided by the electronic document's chip are protected against attacks with high attack potential.

Protection against Abuse of Functionality:

The TOE must prevent that functions of the TOE, which may not be used in TOE operational phase, can be abused in order (i) to manipulate or to disclose the User Data stored in the TOE, (ii) to manipulate or to disclose the TSF-data stored in the TOE, (iii) to manipulate (bypass, deactivate or modify) soft-coded security functionality of the TOE.

Protection against Information Leakage:

The TOE must provide protection against disclosure of confidential User Data or/and TSF-data stored and/or processed by the travel document

by measurement and analysis of the shape and amplitude of signals or the time between events found by measuring signals on the electromagnetic field, power consumption, clock, or I/O lines,

by forcing a malfunction of the TOE and/or

by a physical manipulation of the TOE.

Protection against Malfunctions:

The TOE must ensure its correct operation. The TOE must prevent its operation outside the normal operating conditions where reliability and secure operation have not been proven or tested. This is to prevent functional errors in the TOE. The environmental conditions may include external energy (esp. electromagnetic) fields, voltage (on any contacts), clock frequency or temperature. The following TOE security objectives address the aspects of identified threats to be countered involving TOE's environment.

Protection against Physical Tampering:

The TOE must provide protection of confidentiality and integrity of the User Data, the TSF-data and the electronic document's Embedded Software by means of measuring through galvanic contacts representing a direct physical probing on the chip's surface except on pads being bonded (using standard tools for measuring voltage and current) or measuring not using galvanic contacts, but other types of physical interaction between electrical charges (using tools used in solid-state physics research and IC failure analysis), manipulation of the hardware and its security functionality, as well as controlled manipulation of memory contents (User Data, TSF-data) with a prior reverse-engineering to understand the design and its properties and functionality.

OT.Key_Lifecycle_Security

Life cycle security of the keys stored in the TOE

The TOE shall detect flaws during the initialization, Personalization and operational usage. The TOE shall provide safe destruction techniques for the keys (other than the SCD) it stores in case of erasure, re-import or re-generation.

OT.Keys_Secrecy

Secrecy of Keys

The secrecy of the keys (other than the SCD) stored in the TOE is reasonably assured against attacks with a high attack potential.

OT.TOE_AuthKey_Unique

Uniqueness of the TOE authentication key(s)

The TOE shall ensure the cryptographic quality of the asymmetric authentication key pair used for the TOE authentication. The private key used for TOE authentication can practically occur only once and cannot be reconstructed from the public key. In that context 'practically occur once' means that the probability of equal TOE authentication key is negligible low.

OT.Lifecycle_Management

Management of the life cycle

The TOE provides a life cycle management enabling to separate its life cycle in two main phases. The first one (phase 6) is the one during which the TOE is under the sole control of the Personalization Agent. The following operation may be realized:

The SCD, SVD and keys may be created, generated, imported or erased

The PINs/PUK (s) may be created and loaded

SVD and public keys may be exported Once performed, the Personalization Agent switches the TOE in phase 7. This transition is irreversible leaving the TOE under the sole control of the R.Sigy and R.Admin according to the TOE specification and security rules set by the Personalization Agent.

OT.eServices

Provision of eServices

The TOE provides the following mechanisms:

decrypt encryption decipherment keys using asymmetric mechanisms;

digital authentication: authentication of the TOE (on behalf of the TOE holder) using an asymmetric private key;

Moreover, the TOE ensures these keys remain genuine by enforcing an access control over the update of these keys, in order to ensure that only entitled entities can change them.

These mechanisms provided by the electronic document's chip are protected against attacks with high attack potential.

OT.AC_Pers_EAC

Personalization of the Electronic Document

The TOE must ensure that user data and TSF-Data that are permanently stored in the TOE can be written by authorized personalization agents only, with the following exception: an Authentication

Terminal may also write or modify user data according to its effective authorization. The effective authorization is determined by the electronic document during Terminal Authentication.

OT.Tracing

Tracing electronic document

The TOE must prevent gathering TOE tracing data by means of unambiguous identifying the electronic document remotely through establishing or listening to a communication via the contactless interface of the TOE without knowledge of the correct values of shared passwords (PACE passwords) in advance.

6.2 Security Objectives for the Operational Environment

6.2.1 Security Objectives drawn from the Protection Profiles

OE.SVD_Auth

Authenticity of the SVD The operational environment shall ensure the integrity of the SVD sent to the CGA of the CSP. The CGA verifies the correspondence between the SCD in the SSCD of the signatory and the SVD in the qualified certificate.

OE.CGA_QCert

Generation of qualified certificates

The CGA shall generate a qualified certificate that includes (amongst others) the name of the signatory controlling the TOE, the SVD matching the SCD stored in the TOE and being under sole control of the signatory, the advanced signature of the CSP.

The CGA shall confirm with the generated qualified certificate that the SCD corresponding to the SVD is stored in a SSCD.

OE.Dev_Prov_Service

Authentic SSCD provided by SSCD Provisioning Service

The SSCD Provisioning Service handles authentic devices that implement the TOE, prepares the TOE for proof as SSCD to external entities, personalises the TOE for the legitimate user as signatory, links the identity of the TOE as SSCD with the identity of the legitimate user, and delivers the TOE to the signatory.

OE.HID_VAD

Protection of the VAD

If an external device provides the human interface for user authentication, this device shall ensure confidentiality and integrity of the VAD as needed by the authentication method employed from import through its human interface until import through the TOE interface. In particular, if the TOE requires a trusted channel for import of the VAD, the HID shall support usage of this trusted channel.

OE.DTBS_Intend

SCA sends data intended to be signed

The signatory shall use a trustworthy SCA that generates the DTBS/R of the data that has been presented as DTBS and which the signatory intends to sign in a form which is appropriate for signing by the TOE, sends the DTBS/R to the TOE and enables verification of the integrity of the DTBS/R by the TOE, attaches the signature produced by the TOE to the data or provides it separately.

OE.DTBS_Protect

SCA protects the data intended to be signed

The operational environment shall ensure that the DTBS/R cannot be altered in transit between the SCA and the TOE. In particular, if the TOE requires a trusted channel for import of the DTBS/R, the SCA shall support usage of this trusted channel.

OE.Signatory

Security obligation of the signatory

The signatory shall check that the SCD stored in the SSCD received from SSCD-provisioning service is in non-operational state. The signatory shall keep their VAD confidential.

OE.SCD/SVD_Auth_Gen

Authorized SCD/SVD generation

The CSP shall provide security features to ensure that authorised users only may invoke the generation of the SCD and the SVD.

OE.SCD_Secrecy

SCD Secrecy

The CSP shall protect the confidentiality of the SCD during generation and export to the TOE. The CSP shall not use the SCD for creation of any signature and shall irreversibly delete the SCD in the operational environment after export to the TOE.

OE.SCD_Unique

Uniqueness of the signature creation data

The CSP shall ensure the cryptographic quality of the SCD/SVD pair, which is generated in the environment, for the qualified or advanced electronic signature. The SCD used for signature creation shall practically occur only once, i.e. the probability of equal SCDs shall be negligible, and the SCD shall not be reconstructable from the SVD.

OE.SCD_SVD_Corresp

Correspondence between SVD and SCD

The CSP shall ensure the correspondence between the SVD and the SCD generated by the CSP. This includes the correspondence between the SVD sent to the CGA and the SCD exported to the TOE of the signatory identified in the SVD certificate.

OE.CGA_SSCD_Auth

Pre-initialisation of the TOE for SSCD authentication

The CSP shall check by means of the CGA whether the device presented for application of a (qualified) certificate holds unique identification as SSCD, successfully proved this identity as SSCD to the CGA, and whether this identity is linked to the legitimate holder of the device as applicant for the certificate.

OE.CGA_TC_SVD_Imp

CGA trusted channel for SVD import

The CGA shall detect alteration of the SVD imported from the TOE with the claimed identity of the SSCD.

6.2.2 Additional Security Objectives for the Operational Environment

OE.LinkSCD_QualifiedCertificate

Link between SCD stored in the TOE and the relevant qualified certificate

The Role in charge of creating and updating the SCD (**Personalization Agent, R.Admin**), or the trusted IT entity involved in the updating process (CSP) shall ensure an unambiguous link between the (qualified) certificate(s) and the corresponding SCD(s). This link might be figured out by a PKCS#15 structure, an XML structure, an identifier linking the file containing the (qualified) certificate or the URL hosting them to the SCD(s) stored in the TOE. In particular, it implies this link is updated, each time the SCD(s) is created, imported, erased or generated.

OE.AuthKey_Transfer

Secure transfer of authentication key(s) to the TOE

The entity in charge of generating the authentication keys to be loaded in the TOE shall ensure the confidentiality of the key(s) transferred to the TOE.

OE.AuthKey_Unique

Uniqueness of the authentication key(s)

The entity in charge of generating the authentication keys to be loaded in the TOE shall ensure the cryptographic quality of the authentication key(s). The authentication key used for authentication can practically occur only once and, in case of a TOE authentication key cannot be reconstructed from its public portion. In that context 'practically occur once' means that the probability of equal keys is negligible low.

OE.TOE_PublicKeyAuth_Transfer

Secure transfer of public authentication key(s) of the TOE

The entity in charge of generating the authentication certificate from the TOE's authentication public key generated in the TOE shall ensure the authenticity of this data when transferred from the TOE. This may be achieved through operational measures.

OE.Terminal_Authentication

Authentication Key pairs needed for Terminal Authentication

The electronic document issuer shall establish a public key infrastructure for the card verifiable certificates used for Terminal Authentication. For this aim, the electronic document issuer shall run a Country Verifying Certification Authority. The instances of the PKI shall fulfill the requirements and rules of the corresponding certificate policy. The electronic document issuer shall make the CVCA certificate available to the personalization agent or the manufacturer.

OE.Legislative_Compliance

Issuing of the electronic document

The electronic document Issuer must issue the electronic document and approve it using the terminals complying with all applicable laws and regulations.

OE.Passive_Auth_Sign

Authentication of electronic document by Signature

The electronic document Issuer has to establish the necessary public key infrastructure as follows: the Issuer CA acting on behalf and according to the policy of the electronic document Issuer must (i) generate a cryptographically secure Issuer CA Key Pair, (ii) ensure the secrecy of the Issuer CA Private Key and issue certificate for its Sub-CA in a secure operational environment (if needed), and (iii) publish its certificate. Hereby authenticity and integrity of these certificates are being maintained. An Issuer CA acting in accordance with the Issuer CA policy must generate digital seals protecting the content of electronic document in a secure operational environment only.

The Issuer CA must issue its certificates exclusively to the rightful organizations (and must sign exclusively correct digital seals to be stored on electronic document).

OE.Personalization

Personalization of electronic document

The electronic document Issuer must ensure that the Personalization Agents acting on his behalf (i) store the corresponding data in the electronic document (electronic Personalization) for the electronic document holder, (ii) write the document details data, (iii) write the initial TSF data, (iv) sign the digital seal protecting the content of the electronic document.

OE.Terminal

Terminal operating

The terminal operators must operate their terminals as follows:

The related terminals are used by terminal operators and by electronic document holders.

The related terminals implement the terminal parts of the PACE protocol and check the digital seal generated by the Issuer CA included in the electronic document and protecting its content. The BAT shall use randomly and (almost) uniformly selected nonces, if required by the protocols (for generating ephemeral keys for Diffie-Hellmann).

The related terminals securely store the Issuer CA certificate in order to be able to verify the digital seals generated by the Issuer CA and included in the electronic document to protect its content (integrity and authenticity of the data stored in the electronic document).

The related terminals and their environment must ensure confidentiality and integrity of respective data handled by them (e.g. confidentiality of the PACE passwords or the PIN, integrity of PKI certificates, etc.), where it is necessary for a secure operation of the TOE.

OE.Electronic_Document_Holder

Electronic document holder Obligations

The electronic document holder may reveal, if necessary, his or her verification values of the PACE password or the PIN to an authorized person or device who definitely act according to respective regulations and are trustworthy.

6.3 Security Objectives Rationale

6.3.1 Threats

6.3.1.1 Threats drawn from the Protection Profiles

T.SCD_Divulg addresses the threat against the legal validity of electronic signature due to storage and copying of SCD outside the TOE. This threat is countered by

OE.SCD_Secrecy, which assures the secrecy of the SCD in the CSP environment, and

OT.SCD_Secrecy, which assures the secrecy of the SCD during use by the TOE for signature creation. Furthermore, generation and/or import of SCD known by an attacker is countered by

OE.SCD/SVD_Auth_Gen, which ensures that only authorized SCD generation in the environment is possible, and OT.SCD_Auth_Imp, which ensures that only authorised SCD import is possible.

T.SCD_Derive deals with attacks on the SCD via public known data produced by the TOE, which are the SVD and the signatures created with the SCD.

OT.SCD/SVD_Auth_Gen counters this threat by implementing cryptographically secure generation of the SCD/SVD pair.

OT.Sig_Secure ensures cryptographically secure electronic signatures.

OE.SCD_Unique counters this threat by implementing cryptographically secure generation of the SCD/SVD pair.

T.Hack_Phys deals with physical attacks exploiting physical vulnerabilities of the TOE.

OT.SCD_Secrecy preserves the secrecy of the SCD. OT.EMSEC_Design counters physical attacks through the TOE interfaces and observation of TOE emanations. OT.Tamper_ID and

OT.Tamper_Resistance counter the threat T.Hack_Phys by detecting and resisting tampering attacks.

OT.Keys_Secrecy preserves the secrecy of all the authentication and eServices keys stored in the TOE.

T.SVD_Forgery deals with the forgery of the SVD exported by the TOE to the CGA for certificate generation. T.SVD_Forgery is addressed by

OT.SCD_SVD_Corresp, which ensures correspondence between SVD and SCD and unambiguous reference of the SVD/SCD pair for the SVD export and signature creation with the SCD, and OE.SVD_Auth that ensures the integrity of the SVD exported by the TOE to the CGA.

OE.SCD_SVD_Corresp, which ensures correspondence between SVD and SCD.

Additionally T.SVD_Forgery is addressed by OT.TOE_TC_SVD_Exp, which ensures that the TOE sends the SVD in a verifiable form through a trusted channel to the CGA, as well as by

OE.CGA_TC_SVD_Imp, which provides verification of SVD authenticity by the CGA.

T.SigF_Misuse addresses the threat of misuse of the TOE signature creation function to create SDO by others than the signatory to create an electronic signature on data for which the signatory has not expressed the intent to sign, as required by paragraph 1(c) of Annex III. OT.Lifecycle_Security

(Lifecycle security) requires the TOE to detect flaws during the initialisation, personalisation and operational usage including secure destruction of the SCD, which may be initiated by the signatory.

OT.Sig_SigF (Signature creation function for the legitimate signatory only) ensures that the TOE

provides the signature creation function for the legitimate signatory only. OE.DTBS_Intend (Data intended to be signed) ensures that the SCA sends the DTBS/R only for data the signatory intends to sign and OE.DTBS_Protect counters manipulation of the DTBS during transmission over the channel between the SCA and the TOE.

OT.DTBS_Integrity_TOE (DTBS/R integrity inside the TOE) prevents the DTBS/R from alteration inside the TOE. If the SCA provides a human interface for user authentication, OE.HID_VAD (Protection of

the VAD) provides confidentiality and integrity of the VAD as needed by the authentication method employed. OE.Signatory ensures that the signatory checks that an SCD stored in the SSCD when

received from an SSCD-provisioning service provider is in non-operational state, i.e. the SCD cannot be used before the signatory becomes control over the SSCD. OE.Signatory ensures also that the signatory keeps their VAD confidential.

OT.Lifecycle_Management ensures that when the TOE is under the Personalization Agent control, it cannot be misused to sign on behalf of the legitimate Signatory.

T.DTBS_Forgery addresses the threat arising from modifications of the data sent as input to the TOE's signature creation function that does not represent the DTBS as presented to the signatory and for which the signature has expressed its intent to sign. The TOE IT environment addresses

T.DTBS_Forgery by the means of OE.DTBS_Intend, which ensures that the trustworthy SCA generates the DTBS/R of the data that has been presented as DTBS and which the signatory intends to sign in a form appropriate for signing by the TOE, and by means of OE.DTBS_Protect, which ensures that the DTBS/R cannot be altered in transit between the SCA and the TOE. The TOE counters this threat by the means of OT.DTBS_Integrity_TOE by ensuring the integrity of the DTBS/R inside the TOE.

T.Sig_Forgery deals with non-detectable forgery of the electronic signature. OT.Sig_Secure, OT.SCD_Unique and OE.CGA_QCert address this threat in general. OT.Sig_Secure (Cryptographic security of the electronic signature) ensures by means of robust cryptographic techniques that the

signed data and the electronic signature are securely linked together. OT.SCD_Unique ensures that the same SCD cannot be generated more than once and the corresponding SVD cannot be included in another certificate by chance. OE.CGA_QCert prevents forgery of the certificate for the corresponding SVD, which would result in false verification decision concerning a forged signature. OE.SCD_Unique ensures that the same SCD cannot be generated more than once and the corresponding SVD cannot be included in another certificate by chance.

6.3.1.2 Additional Threats

T.Key_Divulg addresses the threat against the (1) authentication key of the TOE, (2) the authentication keys of entities and (3) the eServices keys stored in the TOE due to storage and copying of key(s) outside the TOE. This threat is countered by OT.Keys_Secrecy which assures the secrecy of the keys stored and used by the TOE. OE.AuthKey_Transfer ensures the confidentiality of the authentication keys transferred to the TOE. OT.Key_Lifecycle_Security (Lifecycle security) ensures the secrecy of the keys stored in the TOE during the whole life of the TOE.

T.Key_Derive deals with attacks on authentication and eServices keys via public known data produced or received by the TOE (public key, authentication cryptogram,...). This threat is countered by OE.AuthKey_Unique (in case of import) and OT.TOE_AuthKey_Unique (in case of TOE's authentication key generation) that provides cryptographic secure generation of the keys. OT.Authentication_Secure ensures secure authentication cryptograms.

T.TOE_PublicAuthKey_Forgery deals with the forgery of the TOE's public key used for authentication exported by the TOE to an entitled entity for the generation of the certificate. This is addressed by OE.TOE_PublicKeyAuth_Transfer which ensures the authenticity of the TOE's public key for authentication.

T.Authentication_Replay deals with the threats when an attacker retrieves an authentication cryptogram presented to the TOE by an entity and presents it again to the TOE in order to grant some rights and gain access to some data on the TOE. This threat is addressed by OT.Authentication_Secure that ensures the authentication cryptogram can not be replayed as they rely on random data internally generated by the TOE.

T.Counterfeit addresses the attack of an unauthorized copy or reproduction of the genuine electronic document. This attack is countered by the proof of the chip's authenticity, as aimed by OT.Authentication_Secure using a Chip Authentication key pair that is generated within the issuing PKI branch, as aimed by OE.AuthKey_Transfer, OE.AuthKey_Unique, OE.TOE_PublicKeyAuth_Transfer.

T.Sensitive_Data is countered by the TOE-Objective OT.Authentication_Secure, that requires that read access to sensitive user data is only granted to Authentication Terminals with corresponding access rights. Furthermore, it is required that the confidentiality of the data is ensured during contactless transmission. The objective OE.Terminal_Authentication requires the electronic document issuer to provide the public key infrastructure (PKI) to generate and distribute the card verifiable certificates needed by the electronic document to securely authenticate the Authentication Terminal.

T.Abuse-Func addresses attacks of misusing TOE's functionality to manipulate or to disclosure the stored User- or TSF-data as well as to disable or to bypass the soft-coded security functionality. The security objective OT.Authentication_Secure ensures that the usage of functions having not to be used in the operational phase is effectively prevented.

T.Eavesdropping addresses listening to the contactless communication between the TOE and a BAT or an Authentication Terminal in order to gain access to transferred user data. This threat is countered by the security objective OT.Authentication_Secure through a trusted channel based on PACE or EAC Authentication.

T.Forgery addresses the fraudulent, complete or partial alteration of user data and/or TSF-Data stored on the TOE, and/or exchanged between the TOE and the terminal. The threat T.Forgery addresses the fraudulent, complete or partial alteration of the User Data or/and TSF-data stored on the TOE or/and exchanged between the TOE and the terminal. The security objective OT.AC_Pers_EAC requires the TOE to limit the write access for the travel document to the trustworthy Personalization Agent (cf. OE.Personalization). The TOE will protect the integrity and authenticity of the stored and exchanged User Data or/and TSF-data as aimed by the security objective OT.Authentication_Secure. This objective contribute also to protecting integrity of the User Data

or/and TSF-data stored on the TOE. A terminal operator operating his terminals according to OE.Terminal and performing the digital seal verification as aimed by OE.Passive_Auth_Sign will be able to effectively verify integrity and authenticity of the data received from the TOE.

T.Information Leakage is typical for integrated circuits like smart cards under direct attack with high attack potential. The protection of the TOE against this threat is addressed by the directly related security objective OT.Authentication_Secure.

T.Malfunction is typical for integrated circuits like smart cards under direct attack with high attack potential. The protection of the TOE against this threat is addressed by the directly related security objectives OT.Authentication_Secure.

T.Phys-Tamper is typical for integrated circuits like smart cards under direct attack with high attack potential. The protection of the TOE against this threat is addressed by the directly related security objective OT.Authentication_Secure.

T.Skimming addresses accessing the user data (stored on the TOE or transferred between the TOE and the terminal) using the TOE's contactless interface. This threat is countered by the security objective OT.Authentication_Secure through the PACE authentication. The objective OE.Electronic_Document_Holder ensures that a PACE session can only be established either by the travel document holder itself or by an authorised person or device, and, hence, cannot be captured by an attacker. Additionally, the threat is also addressed by OT.Authentication_Secure that demands a trusted channel based on Chip Authentication, and requires that read access to sensitive user data is only granted to Authentication Terminals with corresponding access rights. Moreover, OE.Terminal_Authentication requires the electronic document issuer to provide the corresponding PKI.

T.Tracing addresses gathering TOE tracing data identifying it remotely by establishing or listening to a communication via the contactless interface of the TOE, whereby the attacker does not a priori know the correct values of the PACE password. This threat is directly countered by security objectives OT.Tracing (no gathering TOE tracing data) and OE.Electronic_Document_Holder (the attacker does not a priori know the correct values of the shared passwords).

6.3.2 Organisational Security Policies

6.3.2.1 Security Policies drawn from the Protection Profiles

P.CSP_QCert establishes the CSP generating qualified certificate or non-qualified certificate linking the signatory and the SVD implemented in the SSCD under sole control of this signatory. P.CSP_QCert is addressed by

OT.Lifecycle_Security, which requires the TOE to detect flaws during the initialisation, personalisation and operational usage,

OT.SCD_SVD_Corresp, which requires to ensure the correspondence between the SVD and the SCD during their generation,

OE.SCD/SVD_Auth_Gen, which ensures that the SCD/SVD generation can be invoked by authorized users only,

OT.SCD_Auth_Imp which ensures that authorised users only may invoke the import of the SCD,

OE.SCD_SVD_Corresp, which requires the CSP to ensure the correspondence between the SVD and the SCD during their generation, and

OE.CGA_QCert for generation of qualified certificates or non-qualified certificates, which requires the CGA to certify the SVD matching the SCD implemented in the TOE under sole control of the signatory.

According to OT.TOE_SSCD_Auth the copies of the TOE will hold unique identity and authentication data as SSCD and provide security mechanisms enabling the CGA to identify and to authenticate the TOE as SSCD to prove this identity as SSCD to the CGA. The OE.CGA_SSCD_Auth ensures that the SP checks the proof of the device presented of the applicant that it is a SSCD.

P.QSign provides that the TOE and the SCA may be employed to sign data with an advanced electronic signature, which is a qualified electronic signature if based on a valid qualified certificate.

OT.Sigy_SigF ensures signatory's sole control of the SCD by requiring the TOE to provide the signature creation function for the legitimate signatory only and to protect the SCD against the use of others. OT.Sig_Secure ensures that the TOE creates electronic signatures, which cannot be forged without knowledge of the SCD through robust encryption techniques. OE.CGA_QCert addresses the requirement of qualified or non-qualified electronic certificates building a base for the electronic

signature. OE.DTBS_Intend ensures that the SCA provides only those DTBS to the TOE, which the signatory intends to sign.

P.Sigy_SSCD requires the TOE to meet Annex II [REG]. This is ensured as follows:

OE.SCD_Unique meets the regulation [REG], Annex II, by the requirements that the SCD used for signature creation can practically occur only once;

OT.SCD_Unique meets Annex II [REG], by the requirements that the SCD used for signature creation can practically occur only once;

OT.SCD_Unique, OT.SCD_Secrecy and OT.Sig_Secure meet the requirement in Annex II [REG] by the requirements to ensure secrecy of the SCD.

OT.EMSEC_Design and OT.Tamper_Resistance address specific objectives to ensure secrecy of the SCD against specific attacks;

OT.SCD_Auth_Imp, which limits SCD import to authorised users only;

OE.SCD_Secrecy, which ensures the confidentiality of the SCD during generation and export to the TOE, and deletes the SCD after export to the TOE. The CSP does not use the SCD for signature creation;

OT.SCD_Secrecy and OT.Sig_Secure meet the requirement in Annex II [REG] by the requirements to ensure that the SCD cannot be derived from SVD, the electronic signatures or any other data exported outside the TOE; — OT.SCD/SVD_Auth_Gen, which limits invocation of the generation of the SCD and the SVD to authorised users only, and

OT.Sigy_SigF meets the requirement in Annex II [REG] by the requirements to ensure that the TOE provides the signature creation function for the legitimate signatory only and protects the SCD against the use of others;

OT.DTBS_Integrity_TOE meets the requirements in Annex II [REG] as the TOE must not alter the DTBS/R.

Annex II [REG] requires that a SSCD does not prevent the data to be signed from being presented to the signatory prior to the signature process is obviously fulfilled by the method of TOE usage: the SCA will present the DTBS to the signatory and send it to the SSCD for signing.

The usage of SCD under sole control of the signatory is ensured by

OT.Lifecycle_Security requiring the TOE to detect flaws during the initialisation, personalisation and operational usage,

OE.SCD/SVD_Auth_Gen, which limits invocation of the generation of the SCD and the SVD to authorised users only,

OT.Sigy_SigF, which requires the TOE to provide the signature creation function for the legitimate signatory only and to protect the SCD against the use of others. OE.Dev_Prov_Service ensures that the legitimate user obtains a TOE sample as an authentic, initialised and personalised TOE from an SSCD Provisioning Service through the TOE delivery procedure. If the TOE implements SCD generated under control of the SSCD Provisioning Service the legitimate user receives the TOE as SSCD. If the TOE is delivered to the legitimate user without SCD In the operational phase he or she applies for the (qualified) certificate as the Device holder and legitimate user of the TOE. The CSP will use the TOE security feature (addressed by the security objectives OT.TOE_SSCD_Auth and OT.TOE_TC_SVD_Exp) to check whether the device presented is a SSCD linked to the applicant as required by

OE.CGA_SSCD_Auth and the received SVD is sent by this SSCD as required by OE.CGA_TC_SVD_Imp. Thus the obligation of the SSCD provision service for the first SCD/SVD pair is complemented in an appropriate way by the CSP for the SCD/SVD pair generated outside the secure preparation environment.

P.Sig_Non-Repud deals with the repudiation of signed data by the signatory, although the electronic signature is successfully verified with the SVD contained in their certificate valid at the time of signature creation. This policy is implemented by the combination of the security objectives for the TOE and its operational environment, which ensures the aspects of signatory's sole control over and responsibility for the electronic signatures created with the TOE.

OE.SCD/SVD_Auth_Gen, OE.SCD_Secrecy and OE.SCD_Unique ensure the security of the SCD in the CSP environment. OE.SCD_Secrecy ensures the confidentiality of the SCD during generation, during and after export to the TOE. The CSP does not use the SCD for creation of any signature and deletes the SCD irreversibly after export to the TOE. OE.SCD_Unique provides that the signatory's SCD can

practically occur just once. OE.SCD_SVD_Corresp ensures that the SVD in the certificate of the signatory corresponds to the SCD that is implemented in the copy of the TOE of the signatory. OE.CGA_QCert ensures that the certificate allows to identify the signatory and thus to link the SVD to the signatory. OE.SVD_Auth and OE.CGA_QCert require the environment to ensure authenticity of the SVD as being exported by the TOE and used under sole control of the signatory. OT.SCD_SVD_Corresp ensures that the SVD exported by the TOE corresponds to the SCD that is implemented in the TOE. OT.SCD_Unique provides that the signatory's SCD can practically occur just once.

OE.Signatory ensures that the signatory checks that the SCD, stored in the SSCD received from an SSCD provisioning service is in non-operational state (i.e. the SCD cannot be used before the signatory becomes into sole control over the SSCD). OT.Sigy_SigF provides that only the signatory may use the TOE for signature creation. As prerequisite OE.Signatory ensures that the signatory keeps their VAD confidential. OE.DTBS_Intend, OE.DTBS_Protect and OT.DTBS_Integrity_TOE ensure that the TOE creates electronic signatures only for those DTBS/R, which the signatory has decided to sign as DTBS. The robust cryptographic techniques required by OT.Sig_Secure ensure that only this SCD may create a valid electronic signature that can be successfully verified with the corresponding SVD used for signature verification. The security objective for the TOE OT.Lifecycle_Security (Lifecycle security), OT.SCD_Secrecy (Secrecy of the signature creation data), OT.EMSEC_Design (Provide physical emanations security), OT.Tamper_ID (Tamper detection) and OT.Tamper_Resistance (Tamper resistance) protect the SCD against any compromise.

The TOE security feature addressed by the security objectives OT.TOE_SSCD_Auth and OT.TOE_TC_SVD_Exp supported by OE.Dev_Prov_Service enables the verification whether the device presented by the applicant is a SSCD as required by OE.CGA_SSCD_Auth and the received SVD is sent by the device holding the corresponding SCD as required by OE.CGA_TC_SVD_Imp.

OE.DTBS_Intend (SCA sends data intended to be signed), OE.DTBS_Protect OT.DTBS_Integrity_TOE (DTBS/R integrity inside the TOE) ensure that the TOE generates electronic signatures only for a DTBS/R that the signatory has decided to sign as DTBS. The robust cryptographic techniques required by OT.Sig_Secure ensure that only this SCD may create a valid electronic signature that can be successfully verified with the corresponding SVD used for signature verification. The security objective for the TOE OT.Lifecycle_Security (Lifecycle security), OT.SCD_Secrecy (Secrecy of the signature creation data), OT.EMSEC_Design (Provide physical emanations security), OT.Tamper_ID (Tamper detection) and OT.Tamper_Resistance (Tamper resistance) protect the SCD against any compromise. OT.LifeCycle_Management ensures that when the TOE is under the Personalization Agent control, it can not be misused to sign on behalf of the legitimate Signatory. OE.LinkSCD_QualifiedCertificate ensure the SCA always uses the SCD it intends to, in order to create a digital signature. OE.LinkSCD_QualifiedCertificate ensures that the SCA can unambiguously sort out within the TOE file structure the SCD matching any (qualified) certificate it has chosen and intends to use.

6.3.2.2 Additional Security Policies

P.LinkSCD_QualifiedCertificate ensures that the SCA can unambiguously find within the TOE File structure the SCD matching a (qualified) certificate it has chosen to perform an electronic signature. It is addressed by OE.LinkSCD_QualifiedCertificate that ensures an unambiguous link between each (qualified) certificate and the matching SCD loaded in the TOE.

P.TOE_PublicAuthKey_Cert ensures that each private key(s) of the TOE for authentication matches the public key stored within the relevant certificate issued by an entitled entity. The authentication public key is exported thanks to OE.TOE_PublicKeyAuth_Transfer.

P.eServices ensures that the TOE provides secure eServices functionalities. It is addressed by OT.eServices.

P.EAC_Terminal addresses the requirement for Authentication Terminals to implement the terminal parts of the protocols needed to executed EAC according to its specification in [TR_03110], and to store (static keys) or generate (temporary keys and nonces) the needed related credentials. This is enforced by OE.AuthKey_Transfer, OE.AuthKey_Unique and OE.TOE_PublicKeyAuth_Transfer which require Chip Authentication and Restricted Identity keys to be correctly generated and stored, by OE.Terminal_Authentication for the PKI needed for Terminal Authentication, and by OE.Terminal which covers the PACE protocol and the digital seal verification.

P.Terminal_PKI is enforced by establishing the receiving PKI branch as aimed by the objective OE.Terminal_Authentication.

P.Card_PKI is enforced by establishing the issuing PKI branch as aimed by the objective OE.Passive_Auth_Sign (for the digital seal verification).

P.Pre-Operational is enforced by the following security objectives: (i) OT.AC_Pers_EAC and OE.Personalization together enforce the OSP's properties 'correctness of the User- and the TSF-data stored' and 'authorisation of Personalization Agents'; (ii) OE.Legislative_Compliance is affine to the OSP's property 'compliance with laws and regulations'.

P.Terminal is obviously enforced by the objective OE.Terminal, whereby the one-to-one mapping between the related properties is applicable.

P.Trustworthy_PKI is enforced by OE.Passive_Auth_Sign (for Issuer CA, issuing PKI branch).

6.3.3 Assumptions

A.CGA establishes the protection of the authenticity of the signatory's name and the SVD in the qualified certificate by the advanced signature of the CSP by means of the CGA. This is addressed by OE.CGA_QCert (Generation of qualified certificates), which ensures the generation of qualified certificates, and by OE.SVD_Auth (Authenticity of the SVD), which ensures the protection of the integrity of the received SVD and the verification of the correspondence between the SVD and the SCD that is implemented by the SSCD of the signatory.

A.SCA establishes the trustworthiness of the SCA with respect to generation of DTBS/R. This is addressed by OE.DTBS_Intend (Data intended to be signed) which ensures that the SCA generates the DTBS/R of the data that have been presented to the signatory as DTBS and which the signatory intends to sign in a form which is appropriate for being signed by the TOE.

A.CSP establishes several security aspects concerning handling of SCD and SVD by the CSP. That the SCD/SVD generation device can only be used by authorized users is addressed by OE.SCD/SVD_Auth_Gen (Authorized SCD/SVD Generation), that the generated SCD is unique and cannot be derived by the SVD is addressed by OE.SCD_Unique (Uniqueness of the signature creation data), that SCD and SVD correspond to each other is addressed by OE.SCD_SVD_Corresp (Correspondence between SVD and SCD), and that the SCD are kept confidential, are not used for signature generation in the environment and are deleted in the environment once exported to the TOE is addressed by OE.SCD_Secrecy (SCD Secrecy).

6.3.4 SPD and Security Objectives

Threats	Security Objectives	Rationale
T.SCD_Divulg	OT.SCD_Secrecy, OT.SCD_Auth_Imp, OE.SCD/SVD_Auth_Gen, OE.SCD_Secrecy	Section 6.3.1
T.SCD_Derive	OT.SCD/SVD_Auth_Gen, OT.Sig_Secure, OE.SCD_Unique	Section 6.3.1
T.Hack_Phys	OT.SCD_Secrecy, OT.EMSEC_Design, OT.Tamper_ID, OT.Tamper_Resistance, OT.Keys_Secrecy	Section 6.3.1
T.SVD_Forgery	OT.SCD_SVD_Corresp, OE.SVD_Auth, OE.SCD_SVD_Corresp, OT.TOE_TC_SVD_Exp, OE.CGA_TC_SVD_Imp	Section 6.3.1
T.SigF_Misuse	OT.Lifecycle_Security, OT.Sigy_SigF, OT.DTBS_Integrity_TOE, OE.Signatory, OE.DTBS_Intend, OE.HID_VAD, OE.DTBS_Protect, OT.Lifecycle_Management	Section 6.3.1
T.DTBS_Forgery	OT.DTBS_Integrity_TOE, OE.DTBS_Intend, OE.DTBS_Protect	Section 6.3.1

T.Sig_Forgery	OT.SCD_Unique, OT.Sig_Secure, OE.CGA_QCert, OE.SCD_Unique	Section 6.3.1
T.Key_Divulg	OT.Key_Lifecycle_Security, OT.Keys_Secrecy, OE.AuthKey_Transfer	Section 6.3.1
T.Key_Derive	OT.Authentication_Secure, OT.TOE_AuthKey_Unique, OE.AuthKey_Unique	Section 6.3.1
T.TOE_PublicAuthKey_Forgery	OE.TOE_PublicKeyAuth_Transfer	Section 6.3.1
T.Authentication_Replay	OT.Authentication_Secure	Section 6.3.1
T.Counterfeit	OT.Authentication_Secure, OE.AuthKey_Transfer, OE.AuthKey_Unique, OE.TOE_PublicKeyAuth_Transfer	Section 6.3.1
T.Sensitive_Data	OT.Authentication_Secure, OE.Terminal_Authentication	Section 6.3.1
T.Abuse-Func	OT.Authentication_Secure	Section 6.3.1
T.Eavesdropping	OT.Authentication_Secure	Section 6.3.1
T.Forgery	OT.Authentication_Secure, OT.AC_Pers_EAC, OE.Passive_Auth_Sign, OE.Personalization, OE.Terminal	Section 6.3.1
T.Information_Leakage	OT.Authentication_Secure	Section 6.3.1
T.Malfunction	OT.Authentication_Secure	Section 6.3.1
T.Phys-Tamper	OT.Authentication_Secure	Section 6.3.1
T.Skimming	OT.Authentication_Secure, OE.Terminal_Authentication, OE.Electronic_Document_Holder	Section 6.3.1
T.Tracing	OT.Tracing, OE.Electronic_Document_Holder	Section 6.3.1

Table 6 Threats and Security Objectives - Coverage

Security Objectives	Threats
OT.Lifecycle_Security	T.SigF_Misuse
OT.SCD/SVD_Auth_Gen	T.SCD_Derive
OT.SCD_Unique	T.Sig_Forgery
OT.SCD_SVD_Corresp	T.SVD_Forgery
OT.SCD_Auth_Imp	T.SCD_Divulg
OT.SCD_Secrecy	T.SCD_Divulg, T.Hack_Phys
OT.Sig_Secure	T.SCD_Derive, T.Sig_Forgery
OT.Sigy_SigF	T.SigF_Misuse
OT.DTBS_Integrity_TOE	T.SigF_Misuse, T.DTBS_Forgery
OT.EMSEC_Design	T.Hack_Phys
OT.Tamper_ID	T.Hack_Phys
OT.Tamper_Resistance	T.Hack_Phys
OT.TOE_SSCD_Auth	
OT.TOE_TC_SVD_Exp	T.SVD_Forgery

OT.Authentication_Secure	T.Key_Derive, T.Authentication_Replay, T.Counterfeit, T.Sensitive_Data, T.Abuse-Func, T.Eavesdropping, T.Forgery, T.Information_Leakage, T.Malfunction, T.Phys-Tamper, T.Skimming
OT.Key_Lifecycle_Security	T.Key_Divulg
OT.Keys_Secrecy	T.Hack_Phys, T.Key_Divulg
OT.TOE_AuthKey_Unique	T.Key_Derive
OT.Lifecycle_Management	T.SigF_Misuse
OT.eServices	
OT.AC_Pers_EAC	T.Forgery
OT.Tracing	T.Tracing
OE.SVD_Auth	T.SVD_Forgery
OE.CGA_QCert	T.Sig_Forgery
OE.Dev_Prov_Service	
OE.HID_VAD	T.SigF_Misuse
OE.DTBS_Intend	T.SigF_Misuse, T.DTBS_Forgery
OE.DTBS_Protect	T.SigF_Misuse, T.DTBS_Forgery
OE.Signatory	T.SigF_Misuse
OE.SCD/SVD_Auth_Gen	T.SCD_Divulg
OE.SCD_Secrecy	T.SCD_Divulg
OE.SCD_Unique	T.SCD_Derive, T.Sig_Forgery
OE.SCD_SVD_Corresp	T.SVD_Forgery
OE.CGA_SSCD_Auth	
OE.CGA_TC_SVD_Imp	T.SVD_Forgery
OE.LinkSCD_QualifiedCertificate	
OE.AuthKey_Transfer	T.Key_Divulg, T.Counterfeit
OE.AuthKey_Unique	T.Key_Derive, T.Counterfeit
OE.TOE_PublicKeyAuth_Transfer	T.TOE_PublicAuthKey_Forgery, T.Counterfeit
OE.Terminal_Authentication	T.Sensitive_Data, T.Skimming
OE.Legislative_Compliance	
OE.Passive_Auth_Sign	T.Forgery
OE.Personalization	T.Forgery
OE.Terminal	T.Forgery
OE.Electronic_Document_Holder	T.Skimming, T.Tracing

Table 7 Security Objectives and Threats - Coverage

Organisational Security Policies	Security Objectives	Rationale
P.CSP_QCert	OT.Lifecycle_Security, OT.SCD_SVD_Corresp, OE.CGA_QCert, OT.SCD_Auth_Imp, OE.SCD/SVD_Auth_Gen, OE.SCD_SVD_Corresp, OT.TOE_SSCD_Auth, OE.CGA_SSCD_Auth	Section 6.3.2

P.QSign	OT.Sig_Secure, OT.Sigy_SigF, OE.CGA_QCert, OE.DTBS_Intend	Section 6.3.2
P.Sigy_SSCD	OT.Lifecycle_Security, OT.SCD/SVD_Auth_Gen, OT.SCD_Unique, OT.SCD_Secrecy, OT.Sig_Secure, OT.Sigy_SigF, OT.DTBS_Integrity_TOE, OT.EMSEC_Design, OT.Tamper_Resistance, OT.SCD_Auth_Imp, OE.SCD/SVD_Auth_Gen, OE.SCD_Secrecy, OE.SCD_Unique, OT.TOE_SSCD_Auth, OT.TOE_TC_SVD_Exp, OE.Dev_Prov_Service, OE.CGA_TC_SVD_Imp, OE.CGA_SSCD_Auth	Section 6.3.2
P.Sig_Non-Repud	OT.Lifecycle_Security, OT.SCD_Unique, OT.SCD_SVD_Corresp, OT.SCD_Secrecy, OT.Sig_Secure, OT.Sigy_SigF, OT.DTBS_Integrity_TOE, OT.EMSEC_Design, OT.Tamper_ID, OT.Tamper_Resistance, OE.CGA_QCert, OE.SVD_Auth, OE.DTBS_Intend, OE.Signatory, OE.SCD/SVD_Auth_Gen, OE.SCD_Secrecy, OE.SCD_Unique, OE.SCD_SVD_Corresp, OT.TOE_SSCD_Auth, OT.TOE_TC_SVD_Exp, OE.Dev_Prov_Service, OE.CGA_TC_SVD_Imp, OE.CGA_SSCD_Auth, OE.DTBS_Protect, OE.LinkSCD_QualifiedCertificate	Section 6.3.2
P.LinkSCD_QualifiedCertificate	OE.LinkSCD_QualifiedCertificate	Section 6.3.2
P.TOE_PublicAuthKey_Cert	OE.TOE_PublicKeyAuth_Transfer	Section 6.3.2
P.eServices	OT.eServices	Section 6.3.2
P.EAC_Terminal	OE.AuthKey_Transfer, OE.AuthKey_Unique, OE.TOE_PublicKeyAuth_Transfer, OE.Terminal_Authentication, OE.Terminal	Section 6.3.2
P.Terminal_PKI	OE.Terminal_Authentication	Section 6.3.2
P.Card_PKI	OE.Passive_Auth_Sign	Section 6.3.2
P.Pre-Operational	OT.AC_Pers_EAC, OE.Legislative_Compliance, OE.Personalization	Section 6.3.2
P.Terminal	OE.Terminal	Section 6.3.2
P.Trustworthy_PKI	OE.Passive_Auth_Sign	Section 6.3.2

Table 8 OSPs and Security Objectives - Coverage

Security Objectives	Organisational Security Policies
OT.Lifecycle_Security	P.CSP_QCert, P.Sigy_SSCD, P.Sig_Non-Repud
OT.SCD/SVD_Auth_Gen	P.Sigy_SSCD
OT.SCD_Unique	P.Sigy_SSCD, P.Sig_Non-Repud
OT.SCD_SVD_Corresp	P.CSP_QCert, P.Sig_Non-Repud
OT.SCD_Auth_Imp	P.CSP_QCert, P.Sigy_SSCD
OT.SCD_Secrecy	P.Sigy_SSCD, P.Sig_Non-Repud
OT.Sig_Secure	P.QSign, P.Sigy_SSCD, P.Sig_Non-Repud
OT.Sigy_SigF	P.QSign, P.Sigy_SSCD, P.Sig_Non-Repud

OT.DTBS_Integrity_TOE	P.Sigy_SSCD, P.Sig_Non-Repud
OT.EMSEC_Design	P.Sigy_SSCD, P.Sig_Non-Repud
OT.Tamper_ID	P.Sig_Non-Repud
OT.Tamper_Resistance	P.Sigy_SSCD, P.Sig_Non-Repud
OT.TOE_SSCD_Auth	P.CSP_QCert, P.Sigy_SSCD, P.Sig_Non-Repud
OT.TOE_TC_SVD_Exp	P.Sigy_SSCD, P.Sig_Non-Repud
OT.Authentication_Secure	
OT.Key_Lifecycle_Security	
OT.Keys_Secrecy	
OT.TOE_AuthKey_Unique	
OT.Lifecycle_Management	
OT.eServices	P.eServices
OT.AC_Pers_EAC	P.Pre-Operational
OT.Tracing	
OE.SVD_Auth	P.Sig_Non-Repud
OE.CGA_QCert	P.CSP_QCert, P.QSign, P.Sig_Non-Repud
OE.Dev_Prov_Service	P.Sigy_SSCD, P.Sig_Non-Repud
OE.HID_VAD	
OE.DTBS_Intend	P.QSign, P.Sig_Non-Repud
OE.DTBS_Protect	P.Sig_Non-Repud
OE.Signatory	P.Sig_Non-Repud
OE.SCD/SVD_Auth_Gen	P.CSP_QCert, P.Sigy_SSCD, P.Sig_Non-Repud
OE.SCD_Secrecy	P.Sigy_SSCD, P.Sig_Non-Repud
OE.SCD_Unique	P.Sigy_SSCD, P.Sig_Non-Repud
OE.SCD_SVD_Corresp	P.CSP_QCert, P.Sig_Non-Repud
OE.CGA_SSCD_Auth	P.CSP_QCert, P.Sigy_SSCD, P.Sig_Non-Repud
OE.CGA_TC_SVD_Imp	P.Sigy_SSCD, P.Sig_Non-Repud
OE.LinkSCD_QualifiedCertificate	P.Sig_Non-Repud, P.LinkSCD_QualifiedCertificate
OE.AuthKey_Transfer	P.EAC_Terminal
OE.AuthKey_Unique	P.EAC_Terminal
OE.TOE_PublicKeyAuth_Transfer	P.TOE_PublicAuthKey_Cert, P.EAC_Terminal
OE.Terminal_Authentication	P.EAC_Terminal, P.Terminal_PKI
OE.Legislative_Compliance	P.Pre-Operational
OE.Passive_Auth_Sign	P.Card_PKI, P.Trustworthy_PKI
OE.Personalization	P.Pre-Operational
OE.Terminal	P.EAC_Terminal, P.Terminal
OE.Electronic_Document_Holder	

Table 9 Security Objectives and OSPs - Coverage

Assumptions	Security Objectives for the Operational Environment	Rationale
-------------	---	-----------

A.CGA	OE.CGA_QCert, OE.SVD_Auth	Section 6.3.3
A.SCA	OE.DTBS_Intend	Section 6.3.3
A.CSP	OE.SCD/SVD_Auth_Gen, OE.SCD_Secrecy, OE.SCD_Unique, OE.SCD_SVD_Corresp	Section 6.3.3

Table 10 Assumptions and Security Objectives for the Operational Environment - Coverage

Security Objectives for the Operational Environment	Assumptions
OE.SVD_Auth	A.CGA
OE.CGA_QCert	A.CGA
OE.Dev_Prov_Service	
OE.HID_VAD	
OE.DTBS_Intend	A.SCA
OE.DTBS_Protect	
OE.Signatory	
OE.SCD/SVD_Auth_Gen	A.CSP
OE.SCD_Secrecy	A.CSP
OE.SCD_Unique	A.CSP
OE.SCD_SVD_Corresp	A.CSP
OE.CGA_SSCD_Auth	
OE.CGA_TC_SVD_Imp	
OE.LinkSCD_QualifiedCertificate	
OE.AuthKey_Transfer	
OE.AuthKey_Unique	
OE.TOE_PublicKeyAuth_Transfer	
OE.Terminal_Authentication	
OE.Legislative_Compliance	
OE.Passive_Auth_Sign	
OE.Personalization	
OE.Terminal	
OE.Electronic_Document_Holder	

Table 11 Security Objectives for the Operational Environment and Assumptions - Coverage

7 Extended Requirements

7.1 Extended Families

7.1.1 Extended Family FIA_API - Authentication Proof of Identity

7.1.1.1 Description

This family defines functions provided by the TOE to prove their identity and to be verified by an external entity in the TOE IT environment.

Application note 10: The other families of the Class FIA describe only the authentication verification of users' identity performed by the TOE and do not describe the functionality of the user to prove their identity. The following paragraph defines the family FIA_API in the style of the Common Criteria part 2 (cf. [3], chapter 'Explicitly stated IT security requirements (APE_SRE)') from a TOE point of view.

7.1.1.2 Extended Components

Extended Component FIA_API.1

Description

The following actions could be considered for the management functions in FMT: Management of authentication information used to prove the claimed identity.

Definition

FIA_API.1 Authentication Proof of Identity

FIA_API.1.1 The TSF shall provide an [assignment: *authentication mechanism*] to prove the identity of the [assignment: *authorized user or role*].

Dependencies: No dependencies.

7.1.2 Extended Family FPT_EMS - TOE Emanation

7.1.2.1 Description

The additional family FPT_EMS (TOE Emanation) of the Class FPT (Protection of the TSF) is defined here to describe the IT security functional requirements of the TOE. The TOE shall prevent attacks against the SCD and other secret data where the attack is based on external observable physical phenomena of the TOE. Examples of such attacks are evaluation of TOE's electromagnetic radiation, simple power analysis (SPA), differential power analysis (DPA), timing attacks, radio emanation etc. This family describes the functional requirements for the limitation of intelligible emanations. The family FPT_EMS belongs to the Class FPT because it is the class for TSF protection. Other families within the Class FPT do not cover the TOE emanation.

7.1.2.2 Extended Components

Extended Component FPT_EMS.1

Description

This family defines requirements to mitigate intelligible emanations.

FPT_EMS.1 TOE Emanation has two constituents:

FPT_EMS.1.1 Limit of Emissions requires to not emit intelligible emissions enabling access to TSF data or user data.

FPT_EMS.1.2 Interface Emanation requires to not emit interface emanation enabling access to TSF data or user data.

Definition

FPT_EMS.1 TOE Emanation

FPT_EMS.1.1 The TOE shall not emit [assignment: types of emissions] in excess of [assignment: specified limits] enabling access to [assignment: list of types of TSF data] and [assignment: list of types of user data].

FPT_EMS.1.2 The TSF shall ensure [assignment: type of users] are unable to use the following interface [assignment: type of connection] to gain access to [assignment: list of types of TSF data] and [assignment: list of types of user data].

Dependencies: No dependencies.

7.1.3 Extended Family FMT_LIM - Limited capabilities and availability

7.1.3.1 Description

The family FMT_LIM describes the functional requirements for the test features of the TOE. The new functional requirements were defined in the class FMT because this class addresses the management of functions of the TSF. The examples of the technical mechanism used in the TOE show that no other class is appropriate to address the specific issues of preventing abuse of functions by limiting the capabilities of the functions and by limiting their availability.

7.1.3.2 Extended Components

Extended Component FMT_LIM.1

Description

Limited capabilities requires that the TSF is built to provide only the capabilities (perform action, gather information) necessary for its genuine purpose.

Definition

FMT_LIM.1 Limited Capabilities

FMT_LIM.1.1 The TSF shall be designed in a manner that limits their capabilities so that in conjunction with "Limited availability (FMT_LIM.2)" the following policy is enforced [assignment: Limited capability and availability policy].

Dependencies: (FMT_LIM.2)

Extended Component FMT_LIM.2

Description

Limited availability requires that the TSF restrict the use of functions (refer to Limited capabilities (FMT_LIM.1)). This can be achieved, for instance, by removing or by disabling functions in a specific phase of the TOE's lifecycle.

Definition

FMT_LIM.2 Limited Availability

FMT_LIM.2.1 The TSF shall be designed in a manner that limits their availability so that in conjunction with "Limited capabilities (FMT_LIM.1)" the following policy is enforced [assignment: Limited capability and availability policy].

Dependencies: (FMT_LIM.1)

7.1.4 *Extended Family FCS_RND - Generation of random numbers*

7.1.4.1 **Description**

This family defines quality requirements for the generation of random numbers intended to be used for cryptographic purposes.

7.1.4.2 **Extended Components**

Extended Component FCS_RND.1

Description

Generation of random numbers requires that random numbers meet a defined quality metric.

Definition

FCS_RND.1 Quality metric for random numbers

FCS_RND.1.1 The TSF shall provide a mechanism to generate random numbers that meet [assignment: a defined quality metric].

Dependencies: No dependencies.

8 Security Requirements

8.1 Security Functional Requirements

This section describes the requirements imposed on the TOE in order to achieve the security objectives laid down in the previous chapter.

In some of the functional requirements below, the **[Editorially Refined]** tag has been used to signify a small change in the requirement, to adhere to proper English grammar, or to make it more understandable to the reader.

8.1.1 Security Attributes

The security attributes and the related status for the subjects and objects are:

Subject or object the security attribute is associated with	Security Attribute type	Value of the security attribute
S.User	Role	R.Admin, R.Sigy
S.User	SCD/SVD Management	Authorized, Not authorized
SCD	SCD Operational	Yes, No
SCD	SCD Identifier	Arbitrary value

8.1.1.1 SCD/SVD Management

In phase 6

S.Admin is the personalization agent, and as such always has the attribute "SCD/SVD Management" set to "Authorized". Furthermore in that phase, the TOE allows the SCD to be imported or generated.

In phase 7

In that phase, the TOE only supports SCD/SVD generation. The access condition for SCD/SVD generation is granted if the User is successfully authenticated as S.Admin. If this condition is fulfilled, the attribute "SCD/SVD management" is set to "authorized", otherwise it is set to "not authorized".

8.1.1.2 SCD Operational

In phase 6

The attribute "SCD operational" is always set to "No".

In phase 7

The attribute "SCD operational" is set to "yes" as soon as the subject is authenticated as S.Signatory, using the RAD.

8.1.2 SFRs drawn from PP

The following SFRs are drawn from the protection profiles. They are sorted out depending on the life cycle of the TOE.

8.1.2.1 Phase 6 and 7

FCS_CKM.1/SCD/SVD_Generation Cryptographic key generation

FCS_CKM.1.1/SCD/SVD_Generation [Editorially Refined] The TSF shall generate an **SCD/SVD pair** in accordance with a specified cryptographic key generation algorithm **[cryptographic key generation algorithm]** and specified cryptographic key sizes **[cryptographic key sizes]** that meet the following: **[list of standards]**

The assignments of the cryptographic operations are described in the table below:

key generation algorithm	key sizes	list of standards
Key pair over Elliptic Curve	Any elliptic curve from 160 bits up to 521 with prime field p	[IEEE]
RSA Key generation	1024, 1536 and 2048 bits	[ANSIX9.31]

FCS_CKM.4 Cryptographic key destruction

FCS_CKM.4.1 The TSF shall destroy cryptographic keys in accordance with a specified cryptographic key destruction method **overwriting the buffer containing the key with zero** that meets the following: **none**.

Application Note:

This SFR applies to all keys, whether it is the SCD, the SVD or another one. The cryptographic key SCD will be destroyed before the SCD is re-imported or re-generated into the TOE.

FDP_ACC.1/SCD/SVD_Generation Subset access control

FDP_ACC.1.1/SCD/SVD_Generation The TSF shall enforce the **SCD/SVD Generation SFP** on **subjects: S.User,**
objects: SCD, SVD,
operations: generation of SCD/SVD pair.

FDP_ACF.1/SCD/SVD_Generation Security attribute based access control

FDP_ACF.1.1/SCD/SVD_Generation The TSF shall enforce the **SCD/SVD Generation SFP** to objects based on the following: **the user S.User is associated with the security attribute "SCD/SVD Management"**.

FDP_ACF.1.2/SCD/SVD_Generation The TSF shall enforce the following rules to determine if an operation among controlled subjects and controlled objects is allowed: **S.User with the security attribute "SCD/SVD Management" set to "authorised" is allowed to generate SCD/SVD pair.**

FDP_ACF.1.3/SCD/SVD_Generation The TSF shall explicitly authorise access of subjects to objects based on the following additional rules: **none**.

FDP_ACF.1.4/SCD/SVD_Generation The TSF shall explicitly deny access of subjects to objects based on the following additional rules: **S.User with the security attribute "SCD/SVD management" set to "not authorised" is not allowed to generate SCD/SVD pair.**

Application Note:

In phase 7, the S.user can become S.admin after authentication as S.Signatory combined with an Authentication Terminal (TA_CMT).

FDP_ACC.1/SVD_Transfer Subset access control

FDP_ACC.1.1/SVD_Transfer The TSF shall enforce the **SVD Transfer SFP** on **subjects: S.User,**
objects: SVD,
operations: export.

Application Note:

Note that here S.User can be either R.Sigy or R.Admin depending on the personalization done.

FDP_ACF.1/SVD_Transfer Security attribute based access control

FDP_ACF.1.1/SVD_Transfer The TSF shall enforce the **SVD Transfer SFP** to objects based on the following:

the S.User is associated with the security attribute Role,
the SVD.

FDP_ACF.1.2/SVD_Transfer The TSF shall enforce the following rules to determine if an operation among controlled subjects and controlled objects is allowed: **R.Admin is allowed to export SVD.**

FDP_ACF.1.3/SVD_Transfer The TSF shall explicitly authorise access of subjects to objects based on the following additional rules: **none**.

FDP_ACF.1.4/SVD_Transfer The TSF shall explicitly deny access of subjects to objects based on the following additional rules: **none**.

Application Note:

For this operation, S.User is S.Admin.

In phase 6, S.Admin is the "personalization agent" and is always allowed to export the SVD.

In phase 7, S.Admin is the subject allowed to export the SVD.

FDP_ACC.1/SCD_Import Subset access control

FDP_ACC.1.1/SCD_Import The TSF shall enforce the **SCD Import SFP** on

subjects: S.User,

objects: SCD,

operations: import of SCD.

FDP_ACF.1/SCD_Import Security attribute based access control

FDP_ACF.1.1/SCD_Import The TSF shall enforce the **SCD Import SFP** to objects based on the following: **the S.User is associated with the security attribute "SCD/SVD Management"**.

FDP_ACF.1.2/SCD_Import The TSF shall enforce the following rules to determine if an operation among controlled subjects and controlled objects is allowed: **S.User with the security attribute "SCD/SVD Management" set to "authorised" is allowed to import SCD.**

FDP_ACF.1.3/SCD_Import The TSF shall explicitly authorise access of subjects to objects based on the following additional rules: **none**.

FDP_ACF.1.4/SCD_Import The TSF shall explicitly deny access of subjects to objects based on the following additional rules: **S.User with the security attribute "SCD/SVD management" set to "not authorised" is not allowed to import SCD.**

Application Note:

For this operation, S.User is S.Admin.

In phase 6, S.Admin is the "Personalization Agent" and always has the security attribute "SCD/SVD Management" set to "authorized".

In phase 7, SCD import is not allowed.

FDP_RIP.1 Subset residual information protection

FDP_RIP.1.1 The TSF shall ensure that any previous information content of a resource is made unavailable upon the **deallocation of the resource from** the following objects: **SCD, RAD, VAD, Keys, PIN, PUK, Session keys and related data.**

FDP_SDI.2/Persistent Stored data integrity monitoring and action

FDP_SDI.2.1/Persistent The TSF shall monitor user data stored in containers controlled by the TSF for **integrity error** on all objects, based on the following attributes: **integrity checked stored data.**

FDP_SDI.2.2/Persistent Upon detection of a data integrity error, the TSF shall **prohibit the use of the altered data** **inform the S.Sigy about integrity error.**

Application Note:

The following data persistently stored by the TOE has the user data attribute "integrity checked persistent stored data":

SCD

RAD

Keys

FDP_ITC.1/SCD Import of user data without security attributes

FDP_ITC.1.1/SCD The TSF shall enforce the **SCD Import SFP** when importing user data, controlled under the SFP, from outside of the TOE.

FDP_ITC.1.2/SCD [Editorially Refined] The TSF shall ignore any security attributes associated with the **SCD** when imported from outside the TOE.

FDP_ITC.1.3/SCD The TSF shall enforce the following rules when importing user data controlled under the SFP from outside the TOE: **SCD shall be sent by an authorized CSP.**

Application Note:

This SFR only applies in phase 6.

The TOE interacts with a CSP through a SCD/SVD generation application to import the SCD.

Authorized CSP is able to establish a trusted channel with the TOE for SCD transfer as required by FDP_ITC.1.3/SCD.

The authorized CSP is the «Personalization Agent».

FDP_UCT.1/SCD Basic data exchange confidentiality

FDP_UCT.1.1/SCD [Editorially Refined] The TSF shall enforce the **SCD Import SFP to receive SCD** in a manner protected from unauthorised disclosure.

FDP_DAU.2/SVD Data Authentication with Identity of Guarantor

FDP_DAU.2.1/SVD The TSF shall provide a capability to generate evidence that can be used as a guarantee of the validity of **SVD**.

FDP_DAU.2.2/SVD The TSF shall provide **CGA** with the ability to verify evidence of the validity of the indicated information and the identity of the user that generated the evidence.

FIA_UID.1 Timing of identification

FIA_UID.1.1 The TSF shall allow

self-test according to FPT_TST.1, establishing a trusted channel between the CGA and the TOE by means of TSF required by FTP_ITC.1/SVD, establishing a trusted channel between the CSP and the TOE by means of TSF required by FTP_ITC.1/SCD

on behalf of the user to be performed before the user is identified.

FIA_UID.1.2 The TSF shall require each user to be successfully identified before allowing any other TSF-mediated actions on behalf of that user.

FIA_UAU.1 Timing of authentication

FIA_UAU.1.1 The TSF shall allow

self-test according to FPT_TST.1, identification of the user by means of TSF required by FIA_UID.1, establishing a trusted channel between the CGA and the TOE by means of TSF required by FTP_ITC.1/SVD

on behalf of the user to be performed before the user is authenticated.

FIA_UAU.1.2 The TSF shall require each user to be successfully authenticated before allowing any other TSF-mediated actions on behalf of that user.

FIA_API.1 Authentication Proof of Identity

FIA_API.1.1 The TSF shall provide an **authentication mechanism** to prove the identity of the **SSCD**.

Application Note:

The authentication mechanism is achieved as follows:

In phase 6: GP authentication

In phase 6 & 7: an outgoing MAC

FMT_SMR.1 Security roles

FMT_SMR.1.1 The TSF shall maintain the roles **R.Admin and R.Sigy.**

FMT_SMR.1.2 The TSF shall be able to associate users with roles.

FMT_SMF.1 Specification of Management Functions

FMT_SMF.1.1 The TSF shall be capable of performing the following management functions:

**Creation and modification of RAD,
Enabling the signature creation function,
Modification of the security attribute SCD/SVD management, SCD operational,
Change the default value of the security attribute SCD Identifier,
SCD/SVD Generation,
SCD import,
Unblock of RAD,
Initialisation, change, resume, and unblock of PIN and PUK,
Erase of PIN and RAD,
Reinitialisation of PIN.**

FMT_MSA.1/Admin Management of security attributes

FMT_MSA.1.1/Admin The TSF shall enforce the **SCD/SVD Generation SFP and SCD Import SFP** to restrict the ability to **modify** the security attributes **SCD/SVD management** to **R.Admin**.

FMT_MSA.2 Secure security attributes

FMT_MSA.2.1 The TSF shall ensure that only secure values are accepted for **SCD/SVD Management SCD operational**.

FMT_MSA.3 Static attribute initialisation

FMT_MSA.3.1 The TSF shall enforce the **SCD/SVD Generation SFP, SVD Transfer SFP, SCD Import SFP and Signature Creation SFP** to provide **restrictive** default values for security attributes that are used to enforce the SFP.

FMT_MSA.3.2 The TSF shall allow the **authorized identified role** to specify alternative initial values to override the default values when an object or information is created.

Application Note:

The authorized identified roles are defined in the following table depending on the TOE lifecycle phase

Security attribute	Phase	Authorized identified roles
SCD/SVD Management	6&7	R.Admin
SCD Operational	7	R.Sigy

FMT_MSA.4 Security attribute value inheritance

FMT_MSA.4.1 The TSF shall use the following rules to set the value of security attributes:

If S.Admin successfully generates an SCD/SVD pair without S.Sigy being authenticated the security attribute "SCD operational of the SCD" shall be set to "no" as a single operation

If S.Admin imports SCD while S.Sigy is not currently authenticated, the security attribute "SCD operational" of the SCD shall be set to "no" after import of the SCD as a single operation.

If S.Admin imports SCD while S.Sigy is currently authenticated, the security attribute "SCD operational" of the SCD shall be set to "yes" after import of the SCD as a single operation

Application Note:

Third point doesn't apply as SCD import is only possible in phase 6 where the role R.Sigy doesn't exist

FMT_MTD.1/Admin Management of TSF data

FMT_MTD.1.1/Admin The TSF shall restrict the ability to **create** the **RAD** to **R.Admin**.

FPT_EMS.1 TOE Emanation

FPT_EMS.1.1 The TOE shall not emit **side channel emissions** in excess of **limits specified by the state-of-the-art attacks on smart card IC** enabling access to **SCD** and **RAD**.

FPT_EMS.1.2 The TSF shall ensure **all users** are unable to use the following interface **external contact emanations** to gain access to **RAD** and **SCD**.

FPT_FLS.1 Failure with preservation of secure state

FPT_FLS.1.1 The TSF shall preserve a secure state when the following types of failures occur:
self-test according to FPT_TST fails
security violation detected by [PLT] with FAU_ARP.1.

FPT_PHP.1 Passive detection of physical attack

FPT_PHP.1.1 The TSF shall provide unambiguous detection of physical tampering that might compromise the TSF.

FPT_PHP.1.2 The TSF shall provide the capability to determine whether physical tampering with the TSF's devices or TSF's elements has occurred.

FPT_PHP.3 Resistance to physical attack

FPT_PHP.3.1 The TSF shall resist **physical manipulation and physical probing** to the **TSF** by responding automatically such that the SFRs are always enforced.

FPT_TST.1 TSF testing

FPT_TST.1.1 The TSF shall run a suite of self tests **during initial start-up** to demonstrate the correct operation of **the TSF**.

FPT_TST.1.2 The TSF shall provide authorised users with the capability to verify the integrity of **TSF data**.

FPT_TST.1.3 The TSF shall provide authorised users with the capability to verify the integrity of **TSF**.

FTP_ITC.1/SCD Inter-TSF trusted channel

FTP_ITC.1.1/SCD The TSF shall provide a communication channel between itself and another trusted IT product that is logically distinct from other communication channels and provides assured identification of its end points and protection of the channel data from modification or disclosure.

FTP_ITC.1.2/SCD The TSF shall permit **another trusted IT product** to initiate communication via the trusted channel.

FTP_ITC.1.3/SCD The TSF shall initiate communication via the trusted channel for **Data exchange integrity according to FDP_UCT.1/SCD**
None.

FTP_ITC.1/SVD Inter-TSF trusted channel

FTP_ITC.1.1/SVD [Editorially Refined] The TSF shall provide a communication channel between itself and another trusted IT product **CGA** that is logically distinct from other communication channels and provides assured identification of its end points and protection of the channel data from modification or disclosure.

FTP_ITC.1.2/SVD The TSF shall permit **another trusted IT product** to initiate communication via the trusted channel.

FTP_ITC.1.3/SVD [Editorially Refined] The TSF **or the CGA** shall initiate communication via the trusted channel for

data Authentication with Identity of Guarantor according to FIA_API.1 and

FDP_DAU.2/SVD

None.

8.1.2.2 Phase 7

FCS_COP.1/Sign Cryptographic operation

FCS_COP.1.1/Sign The TSF shall perform **Signature Computation** in accordance with a specified cryptographic algorithm **[Algorithm]** and cryptographic key sizes **[Key Size(s)]** that meet the following: **[Standard]**

Algorithm	Key Size(s)	Standard
Signature Computation with Off-Card Hashing: RSA and ECDSA	RSA-1024, 1536 and 2048with PKCS#1 v1.5 and PKCS#1-PSS EC-DSA over elliptic curves of size of-192, 224, 256, 320, 384, 512 and 521 bits SHA-1, 224, 256, 384 and 512	[PKCS#1], [ANSIX9.62]
Signature Computation with On-Card Hashing: ECDSA only	EC-DSA over elliptic curves of size of 192, 224, 256, 320, 384, 512 and 521 SHA-1, 256 and 384	[ANSIX9.62]

FDP_ACC.1/Signature_Creation Subset access control

FDP_ACC.1.1/Signature_Creation The TSF shall enforce the **Signature Creation SFP** on
subjects: S.User,
objects: DTBS/R, SCD,
operations: signature creation.

FDP_ACF.1/Signature_Creation Security attribute based access control

FDP_ACF.1.1/Signature_Creation The TSF shall enforce the **Signature Creation SFP** to objects based on the following:

the user S.User is associated with the security attribute "Role" and the SCD with the security attribute "SCD Operational".

FDP_ACF.1.2/Signature_Creation The TSF shall enforce the following rules to determine if an operation among controlled subjects and controlled objects is allowed: **R.Sigy is allowed to create electronic signatures for DTBS/R with SCD which security attribute "SCD operational" is set to "yes".**

FDP_ACF.1.3/Signature_Creation The TSF shall explicitly authorise access of subjects to objects based on the following additional rules: **none.**

FDP_ACF.1.4/Signature_Creation The TSF shall explicitly deny access of subjects to objects based on the following additional rules: **S.User is not allowed to create electronic signatures for DTBS/R with SCD which security attribute "SCD operational" is set to "no".**

FDP_SDI.2/DTBS Stored data integrity monitoring and action

FDP_SDI.2.1/DTBS The TSF shall monitor user data stored in containers controlled by the TSF for **integrity error** on all objects, based on the following attributes: **integrity checked stored DTBS.**

FDP_SDI.2.2/DTBS Upon detection of a data integrity error, the TSF shall **prohibit the use of the altered data**
inform the S.Sigy about integrity error.

Application Note:

The DTBS/R temporarily stored by the TOE has the user data attribute "integrity checked stored data".

FIA_AFL.1/RAD Authentication failure handling

FIA_AFL.1.1/RAD The TSF shall detect when **an administrator configurable positive integer within 1 and 15** unsuccessful authentication attempts occur related to **consecutive failed authentication attempts.**

FIA_AFL.1.2/RAD When the defined number of unsuccessful authentication attempts has been **met,** the TSF shall **block RAD.**

Application Note:

These SFRs apply to R.Sigy and R.Admin using the PUK to authenticate itself.

FMT_MOF.1 Management of security functions behaviour

FMT_MOF.1.1 The TSF shall restrict the ability to **enable** the functions **signature creation function** to **R.Sigy**.

FMT_MSA.1/Signatory Management of security attributes

FMT_MSA.1.1/Signatory The TSF shall enforce the **Signature Creation SFP** to restrict the ability to **modify** the security attributes **SCD operational** to **R.Sigy**.

FMT_MTD.1/Signatory Management of TSF data

FMT_MTD.1.1/Signatory The TSF shall restrict the ability to **modify and none** the **RAD** to **R.Sigy**.

Application Note:

This requirement applies only to the RAD belonging to S.Sigy.

8.1.3 Additional SFRs

FCS_CKM.1/Session Keys Cryptographic key generation

FCS_CKM.1.1/Session Keys [Editorially Refined] The TSF shall generate session keys in accordance with a specified cryptographic key generation algorithm **key derivation function** and specified cryptographic key sizes

DES keys of 112 bits

AES keys of 128, 192 and 256 bits

that meet the following: **[TR_03110], [GP2.3], [SCP03]**.

FCS_CKM.1/DH_PACE Cryptographic key generation

FCS_CKM.1.1/DH_PACE The TSF shall generate cryptographic keys in accordance with a specified cryptographic key generation algorithm **[cryptographic key generation algorithm]** and specified cryptographic key sizes **[cryptographic key sizes]** that meet the following: **[standard]**

cryptographic key generation algorithm	cryptographic key sizes	standard
ECDH compliant to [ISO_15946]	192 bits to 521 bits	Based on ECDH protocol compliant to [TR_03111]

FCS_COP.1/GP Secret Data Protection Cryptographic operation

FCS_COP.1.1/GP Secret Data Protection The TSF shall perform **GP secret data encryption** in accordance with a specified cryptographic algorithm

SCP02

SCP03 using AES

and cryptographic key sizes

128 bits

128, 192 and 256 bits

that meet the following:

[GP2.3]

[SCP03].

Application Note:

The type of algorithm used by the TOE depends on the configuration set during the javacard open platform Personalization (For more details see [AGD_PRE_PLT]).

The applet provides this service via the platform, it doesn't own and cannot access the keys used to protect secret data. Their import/generation and destruction are managed by the platform.

FCS_COP.1/SM in Confidentiality Cryptographic operation

FCS_COP.1.1/SM in Confidentiality The TSF shall perform **Secure messaging in confidentiality** in accordance with a specified cryptographic algorithm

Encryption with TDES EDE in CBC mode

Encryption with AES in CBC mode

and cryptographic key sizes

128 bits

128 bits, 192 bits and 256 bits

that meet the following:

[GP2.3] and [TR_03110]

[SCP03] and [TR_03110].

Application Note:

This algorithm is used during secure Messaging to ensure confidentiality of incoming and outgoing data.

FCS_COP.1/SM in Integrity Cryptographic operation

FCS_COP.1.1/SM in Integrity The TSF shall perform **Secure messaging in integrity and authenticity** in accordance with a specified cryptographic algorithm

Retail MAC: MAC algorithm 3 with padding method 2 and DES bloc Cipher

CMAC

and cryptographic key sizes

128 bits

128 bits, 192 bits and 256 bits

that meet the following:

[GP2.3] and, [TR_03110]

[SCP03] and [TR_03110].

Application Note:

This algorithm is used during secure Messaging to ensure integrity and authenticity of incoming and outgoing data.

FCS_COP.1/Digital Auth Cryptographic operation

FCS_COP.1.1/Digital Auth The TSF shall perform **Digital Authentication** in accordance with a specified cryptographic algorithm **[Algorithm]** and cryptographic key sizes **[Key Size(s)]** that meet the following: **[Standard]**

Algorithm	Key Size(s)	Standard
Digital authentication with Off-Card Hashing: RSA and ECDSA	RSA-1024, 1536 and 2048 with PKCS#1 v1.5 and PKCS#1-PSS EC-DNA over elliptic curves of size of-192, 224, 256, 320, 384, 512 and 521 bits SHA-1, 224, 256, 384 and 512	[PKCS#1], [ANSIX9.62]
Digital authentication with On-Card Hashing: ECDSA only	EC-DNA over elliptic curves of size of 192, 224, 256, 320, 384, 512 and 521 SHA-1, 256 and 384	[ANSIX9.62]

FCS_COP.1/Enc Key Decipherment Cryptographic operation

FCS_COP.1.1/Enc Key Decipherment The TSF shall perform **Encryption Key Decipherment** in accordance with a specified cryptographic algorithm **[Algorithm]** and cryptographic key sizes **[Key Size(s)]** that meet the following: **[Standard]**

Algorithm	Key Size(s)	Standard
Encryption key decipherment: RSA	RSA-1024, 1536 and 2048 with PKCS#1 OAEP, using SHA-256	[PKCS#1]

Encryption key decipherment: EC-DH	EC-DH over elliptic curves of size of 192, 224, 256, 320, 384, 512 and 521, using SHA-1, 224, 256, 384 and 512	[ANSIX9.62]
---	---	--------------------

FCS_COP.1/SIG_VER Cryptographic operation

FCS_COP.1.1/SIG_VER The TSF shall perform **digital signature verification** in accordance with a specified cryptographic algorithm **[Algorithm]** and cryptographic key sizes **[Key Size(s)]** that meet the following: **[Standard]**

Algorithm	Key Size(s)	Standard
EC-DSA with SHA-1, SHA-224, SHA-256, SHA-384 and SHA-512	Elliptic curves of size of 192 to 521 bits	[TR_03110]
RSA PKCS#1 v1.5 & v2.1 PSS with SHA-1, SHA-256,SHA-512	1024 up to 2048 bits	[TR_03110]

FCS_RND.1 Quality metric for random numbers

FCS_RND.1.1 The TSF shall provide a mechanism to generate random numbers that meet

FCS_RNG.1 Quality metric for random numbers of [PLT].

FIA_UID.1/PACE Timing of identification

FIA_UID.1.1/PACE The TSF shall allow

to establish the communication channel

to carry out the PACE Protocol (PIN, PUK or CAN) according to [TR_03110] and/or the VERIFY PIN command

to read the Initialization Data if it is not disable by TSF

to carry out the Chip Authentication Protocol v.1 according to [TR_03110]

to carry out the Terminal Authentication Protocol v.1 according to [TR_03110]

on behalf of the user to be performed before the user is identified.

FIA_UID.1.2/PACE The TSF shall require each user to be successfully identified before allowing any other TSF-mediated actions on behalf of that user.

FIA_UAU.1/PACE Timing of authentication

FIA_UAU.1.1/PACE The TSF shall allow

to establish the communication channel

to carry out the PACE Protocol (PIN, PUK or CAN) according to [TR_03110] and/or the VERIFY PIN command

to read the Initialization Data if it is not disable by TSF

to identify themselves by selection of the authentication key

to carry out the Chip Authentication Protocol v.1 according to [TR_03110]

to carry out the Terminal Authentication Protocol v.1 according to [TR_03110]

on behalf of the user to be performed before the user is authenticated.

FIA_UAU.1.2/PACE The TSF shall require each user to be successfully authenticated before allowing any other TSF-mediated actions on behalf of that user.

FIA_UAU.4/PACE Single-use authentication mechanisms

FIA_UAU.4.1/PACE The TSF shall prevent reuse of authentication data related to

PACE Protocol (PIN, PUK or CAN) according to [TR_03110]

Authentication Mechanisms based on Triple-DES or AES

Terminal Authentication Protocol v.1 according to [TR_03110].

Application Note:

The Authentication Mechanisms based on Triple-DES or AES is the authentication process performed in phases 5 and 6.

FIA_UAU.5/PACE Multiple authentication mechanisms

FIA_UAU.5.1/PACE The TSF shall provide

PACE Protocol (PIN, PUK or CAN) according to [TR_03110] and/or VERIFY PIN command Mean to verify the integrity and authenticity of the Chip authentication public key Secure messaging in MAC-ENC mode according to [TR_03111] Symmetric Authentication Mechanism based on Triple-DES or AES Terminal Authentication Protocol v.1 according to [TR_03110]

to support user authentication.

FIA_UAU.5.2/PACE The TSF shall authenticate any user's claimed identity according to the following rules:

Having successfully run in contactless the PACE protocol (PIN, PUK or CAN) and/or the VERIFY PIN command, the TOE accepts only received commands with correct message authentication code sent by means of secure messaging with the key agreed with the terminal by means of the PACE protocol.

The establishment of the secure messaging with the PACE protocol is not mandatory if the VERIFY PIN command is used in contact mode.

The TOE accepts the authentication attempt as Personalization Agent by the Authentication Mechanism with Personalization Agent Key(s).

After run of the Chip Authentication Protocol Version 1, the TOE accepts only received commands with correct message authentication code sent by means of secure messaging with key agreed with the terminal by means of the Chip Authentication Mechanism v1.

The TOE accepts the authentication attempt by means of the Terminal Authentication Protocol v.1 only if the terminal uses the public key presented during the Chip Authentication Protocol v.1 and the secure messaging established by the Chip Authentication Mechanism v.1

The TOE accepts the authentication attempt as Personalization Agent by the Authentication Mechanism with Personalization Agent Key(s).

FIA_UAU.6/PACE Re-authenticating

FIA_UAU.6.1/PACE The TSF shall re-authenticate the user under the conditions **each command sent to the TOE after successful run of the PACE protocol shall be verified as being sent by the BAT.**

FIA_UAU.6/EAC Re-authenticating

FIA_UAU.6.1/EAC The TSF shall re-authenticate the user under the conditions **each command sent to the TOE after successful run of the Chip Authentication Protocol Version 1 shall be verified as being sent by the Inspection System.**

FIA_AFL.1/AUTH Authentication failure handling

FIA_AFL.1.1/AUTH The TSF shall detect when **[selection]** unsuccessful authentication attempts occur related to **[list of authentication events]**.

FIA_AFL.1.2/AUTH When the defined number of unsuccessful authentication attempts has been met, the TSF shall **[list of actions]**.

Selection	List of Authentication Events	List of Actions
Positive integer number set to 0x0A	Authentication attempt involving CAN as shared password for PACE	Wait for an increasing time between receiving of the terminal challenge and sending of the TSF response during the PACE authentication attempts

An administrator configurable positive integer within range of acceptable values 0 to 14 consecutive	Consecutive failed authentication attempts using the PIN or PUK as the shared password for PACE leaving a single authentication attempt	Suspend the PIN or the PUK in contactless
'1'	Consecutive failed authentication attempts using the suspended PIN or PUK as the shared password for PACE in contactless mode	Block the PIN or the PUK
An administrator configurable positive integer within range of acceptable values 0 to 15 consecutive	Consecutive failed authentication attempts using the PIN or PUK with VERIFY PIN command	Block the PIN or the PUK
'1'	Personalization agent authentication attempt	slow down exponentially the next authentication

FIA_API.1/TOE Authentication Authentication Proof of Identity

FIA_API.1.1/TOE Authentication The TSF shall provide an **authentication mechanism** to prove the identity of the **document holder**.

Application Note:

The TOE acts as a substitute for the Document holder, to authenticate digitally on its behalf. The authentication mechanism is triggered by the Document holder itself by presenting its PIN to the TOE.

FDP_ACC.1/TRM Subset access control

FDP_ACC.1.1/TRM The TSF shall enforce the **Access Control SFP** on **terminals gaining access User data stored in the TOE (including sensitive user data)**.

FDP_ACF.1/TRM Security attribute based access control

FDP_ACF.1.1/TRM The TSF shall enforce the **the Access Control SFP** to objects based on the following:

Subjects: Terminal, BAT, Authentication Terminal.

Objects: User data stored in the TOE (including sensitive user data),

Security attributes: Terminal Authorization.

FDP_ACF.1.2/TRM The TSF shall enforce the following rules to determine if an operation among controlled subjects and controlled objects is allowed:

A BAT is allowed to read data objects (except sensitive user data) specified in

FDP_ACF.1.1/TRM after successful authentication, as required by FIA_UAU.1/PACE.

Reading, modifying, writing, or using sensitive user data protected by CAV1 and TAV1

(objects specified in FDP_ACF.1.1/TRM) is only allowed to Authentication Terminals

using the following mechanism: The TOE applies the EAC protocol (cf. FIA_UAU.5) to

determine effective authorizations of the terminal. To determine the effective

authorization of a terminal, the chip must calculate a bitwise Boolean 'and' of the relative

authorization contained in the CHAT of the Terminal Certificate, the referenced eService

certification authority Certificate. Based on the terminal type drawn from the CHAT of the

Terminal Certificate, the TOE shall grant the right to read, modify or write sensitive user

data, or perform operations using these sensitive user data.

FDP_ACF.1.3/TRM The TSF shall explicitly authorise access of subjects to objects based on the following additional rules: **none**.

FDP_ACF.1.4/TRM The TSF shall explicitly deny access of subjects to objects based on the following additional rules:

Any terminal not being a BAT or an Authentication Terminal is not allowed to read, to write, to modify, or to use any user data specified in FDP_ACF.1.1/TRM.

In contactless, terminals not using secure messaging are not allowed to read, write, modify, or use any user data specified in FDP_ACF.1.1/TRM.

FDP_UCT.1/TRM Basic data exchange confidentiality

FDP_UCT.1.1/TRM The TSF shall enforce the **Access Control SFP** to **transmit and receive** user data in a manner protected from unauthorised disclosure.

FDP_UIT.1/TRM Data exchange integrity

FDP_UIT.1.1/TRM The TSF shall enforce the **Access Control SFP** to **transmit and receive** user data in a manner protected from **modification, deletion, insertion and replay** errors.

FDP_UIT.1.2/TRM The TSF shall be able to determine on receipt of user data, whether **modification, deletion, insertion and replay** has occurred.

FTP_ITC.1/PACE Inter-TSF trusted channel

FTP_ITC.1.1/PACE [Editorially Refined] The TSF shall provide a communication channel between itself and a **BAT (in contactless mode)** that is logically distinct from other communication channels and provides assured identification of its end points and protection of the channel data from modification or disclosure. **The trusted channel shall be established by performing the PACE protocol according to [TR_03110].**

FTP_ITC.1.2/PACE [Editorially Refined] The TSF shall permit **the BAT (in contactless mode)** to initiate communication via the trusted channel.

FTP_ITC.1.3/PACE The TSF shall initiate communication via the trusted channel for **any data exchange between the TOE and a BAT after PACE (in contactless mode).**

FMT_SMR.1/PACE Security roles

FMT_SMR.1.1/PACE The TSF shall maintain the roles

**Personalization Agent,
Terminal,
BAT,
Country Verifying Certification Authority,
eService certification authority,
Authentication Terminal,
Document holder.**

FMT_SMR.1.2/PACE The TSF shall be able to associate users with roles.

FMT_MTD.1/CVCA_INI Management of TSF data

FMT_MTD.1.1/CVCA_INI The TSF shall restrict the ability to **write** the **initial Country Verifying Certification Authority Public Key, initial Country Verifying Certification Authority Certificate, initial Current Date** to **the Personalization Agent.**

FMT_MTD.1/CVCA_UPD Management of TSF data

FMT_MTD.1.1/CVCA_UPD The TSF shall restrict the ability to **update** the **Country Verifying Certification Authority Public Key, Country Verifying Certification Authority Certificate,** to **Country Verifying Certification Authority.**

FMT_MTD.1/DATE Management of TSF data

FMT_MTD.1.1/DATE The TSF shall restrict the ability to **modify** the **Current Date** to **Country Verifying Certification Authority, eService certification authority, Authentication Terminal.**

FMT_MTD.1/CAPK Management of TSF data

FMT_MTD.1.1/CAPK The TSF shall restrict the ability to **load or generate** the **Chip Authentication Private Key selected in Access Control SFP to the Personalization Agent**.

FMT_MTD.1/KEY_READ Management of TSF data

FMT_MTD.1.1/KEY_READ The TSF shall restrict the ability to **read** the **PACE passwords, Personalization Agent Keys, Chip Authentication Private Key,** to **none**.

FMT_MTD.1/Initialize_PIN Management of TSF data

FMT_MTD.1.1/Initialize_PIN The TSF shall restrict the ability to **write** the **PIN, PUK and CAN, selected in Access Control SFP to the personalization agent**.

FMT_MTD.1/Resume_PIN Management of TSF data

FMT_MTD.1.1/Resume_PIN The TSF shall restrict the ability to **resume** the **suspended PIN or PUK selected in Access Control SFP (in contactless mode) to the electronic document presenter**.

FMT_MTD.1/Change_PIN Management of TSF data

FMT_MTD.1.1/Change_PIN The TSF shall restrict the ability to **change** the **PIN selected in Access Control SFP to the document holder (using the PUK for unblocking)**.

FMT_MTD.1/Unblock_PIN Management of TSF data

FMT_MTD.1.1/Unblock_PIN The TSF shall restrict the ability to **unblock** the **PIN selected in Access Control SFP to the document holder (using the PUK for unblocking)**.

FMT_MTD.1/UnblockChange_RAD Management of TSF data

FMT_MTD.1.1/UnblockChange_RAD The TSF shall restrict the ability to **unblock and optionally change** the **RAD selected in Access Control SFP to** **If change is required, the document holder (using the PUK for unblocking) and an Authentication Terminal (TA_PMT) in accordance with FMT_MTD.1/Signatory; Otherwise if only unblock is required, the document holder (using the PUK for unblocking)**.

FMT_MTD.1/Erase_PIN Management of TSF data

FMT_MTD.1.1/Erase_PIN The TSF shall restrict the ability to **erase** the **PIN or RAD selected in Access Control SFP to an Authentication Terminal (TA_PMT)**.

FMT_MTD.1/Reinitialize_PIN Management of TSF data

FMT_MTD.1.1/Reinitialize_PIN The TSF shall restrict the ability to **(re)initialize** the **PIN selected in Access Control SFP to the document holder (using the PUK)**.

FMT_MTD.1/UnblockChange_PUK Management of TSF data

FMT_MTD.1.1/UnblockChange_PUK The TSF shall restrict the ability to **unblock and change** the **PUK selected in Access Control SFP to an Authentication Terminal (TA_PMT)**.

FMT_MTD.1/TOE State Management of TSF data

FMT_MTD.1.1/TOE State The TSF shall restrict the ability to **switch** the **TOE from phase 6 to phase 7 to the personalization agent**.

FMT_MTD.3 Secure TSF data

FMT_MTD.3.1 The TSF shall ensure that only secure values are accepted for **TSF data of the Terminal Authentication Protocol v1 and the Access Control SFP.**

FMT_LIM.1 Limited Capabilities

FMT_LIM.1.1 The TSF shall be designed in a manner that limits their capabilities so that in conjunction with "Limited availability (FMT_LIM.2)" the following policy is enforced **Deploying Test Features after TOE Delivery does not allow User Data to be disclosed and manipulated, TSF data to be disclosed or manipulated, software to be reconstructed and, substantial information about construction of TSF to be gathered which may enable other attacks.**

FMT_LIM.2 Limited Availability

FMT_LIM.2.1 The TSF shall be designed in a manner that limits their availability so that in conjunction with "Limited capabilities (FMT_LIM.1)" the following policy is enforced **Deploying Test Features after TOE Delivery does not allow User Data to be disclosed and manipulated, TSF data to be disclosed or manipulated, software to be reconstructed and, substantial information about construction of TSF to be gathered which may enable other attacks.**

FPT_EMS.1/PIN-PUK-KEYS TOE Emanation

FPT_EMS.1.1/PIN-PUK-KEYS The TOE shall not emit **side channel emission** in excess of **limits specified by the state of the art attacks on smart card IC** enabling access to **PIN, PUK, Keys** and **none**.

FPT_EMS.1.2/PIN-PUK-KEYS The TSF shall ensure **all users** are unable to use the following interface **external contacts emanations** to gain access to **PIN, PUK, Keys** and **none**.

8.2 Security Assurance Requirements

The Evaluation Assurance Level is EAL5 augmented with AVA_VAN.5 and ALC_DVS.2.

8.2.1 ADV Development

8.2.1.1 ADV_ARC Security Architecture

ADV_ARC.1 Security architecture description

ADV_ARC.1.1D The developer shall design and implement the TOE so that the security features of the TSF cannot be bypassed.

ADV_ARC.1.2D The developer shall design and implement the TSF so that it is able to protect itself from tampering by untrusted active entities.

ADV_ARC.1.3D The developer shall provide a security architecture description of the TSF.

ADV_ARC.1.1C The security architecture description shall be at a level of detail commensurate with the description of the SFR-enforcing abstractions described in the TOE design document.

ADV_ARC.1.2C The security architecture description shall describe the security domains maintained by the TSF consistently with the SFRs.

ADV_ARC.1.3C The security architecture description shall describe how the TSF initialisation process is secure.

ADV_ARC.1.4C The security architecture description shall demonstrate that the TSF protects itself from tampering.

ADV_ARC.1.5C The security architecture description shall demonstrate that the TSF prevents bypass of the SFR-enforcing functionality.

ADV_ARC.1.1E The evaluator shall confirm that the information provided meets all requirements for content and presentation of evidence.

8.2.1.2 ADV_FSP Functional specification

ADV_FSP.5 Complete semi-formal functional specification with additional error information

ADV_FSP.5.1D The developer shall provide a functional specification.

ADV_FSP.5.2D The developer shall provide a tracing from the functional specification to the SFRs.

ADV_FSP.5.1C The functional specification shall completely represent the TSF.

ADV_FSP.5.2C The functional specification shall describe the TSFI using a semi-formal style.

ADV_FSP.5.3C The functional specification shall describe the purpose and method of use for all TSFI.

ADV_FSP.5.4C The functional specification shall identify and describe all parameters associated with each TSFI.

ADV_FSP.5.5C The functional specification shall describe all actions associated with each TSFI.

ADV_FSP.5.6C The functional specification shall describe all direct error messages that may result from an invocation of each TSFI.

ADV_FSP.5.7C The functional specification shall describe all error messages that do not result from an invocation of a TSFI.

ADV_FSP.5.8C The functional specification shall provide a rationale for each error message contained in the TSF implementation yet does not result from an invocation of a TSFI.

ADV_FSP.5.9C The tracing shall demonstrate that the SFRs trace to TSFIs in the functional specification.

ADV_FSP.5.1E The evaluator shall confirm that the information provided meets all requirements for content and presentation of evidence.

ADV_FSP.5.2E The evaluator shall determine that the functional specification is an accurate and complete instantiation of the SFRs.

8.2.1.3 ADV_IMP Implementation representation

ADV_IMP.1 Implementation representation of the TSF

ADV_IMP.1.1D The developer shall make available the implementation representation for the entire TSF.

ADV_IMP.1.2D The developer shall provide a mapping between the TOE design description and the sample of the implementation representation.

ADV_IMP.1.1C The implementation representation shall define the TSF to a level of detail such that the TSF can be generated without further design decisions.

ADV_IMP.1.2C The implementation representation shall be in the form used by the development personnel.

ADV_IMP.1.3C The mapping between the TOE design description and the sample of the implementation representation shall demonstrate their correspondence.

ADV_IMP.1.1E The evaluator shall confirm that, for the selected sample of the implementation representation, the information provided meets all requirements for content and presentation of evidence.

8.2.1.4 ADV_TDS TOE design

ADV_TDS.4 Semiformal modular design

ADV_TDS.4.1D The developer shall provide the design of the TOE.

ADV_TDS.4.2D The developer shall provide a mapping from the TSFI of the functional specification to the lowest level of decomposition available in the TOE design.

ADV_TDS.4.1C The design shall describe the structure of the TOE in terms of subsystems.

ADV_TDS.4.2C The design shall describe the TSF in terms of modules, designating each module as SFR-enforcing, SFR-supporting, or SFR-non-interfering.

ADV_TDS.4.3C The design shall identify all subsystems of the TSF.

ADV_TDS.4.4C The design shall provide a semiformal description of each subsystem of the TSF, supported by informal, explanatory text where appropriate.

ADV_TDS.4.5C The design shall provide a description of the interactions among all subsystems of the TSF.

ADV_TDS.4.6C The design shall provide a mapping from the subsystems of the TSF to the modules of the TSF.

ADV_TDS.4.7C The design shall describe each SFR-enforcing and SFR-supporting module in terms of its purpose and relationship with other modules.

ADV_TDS.4.8C The design shall describe each SFR-enforcing and SFR-supporting module in terms of its SFR-related interfaces, return values from those interfaces, interaction with other modules and called SFR-related interfaces to other SFR-enforcing or SFR-supporting modules.

ADV_TDS.4.9C The design shall describe each SFR-non-interfering module in terms of its purpose and interaction with other modules.

ADV_TDS.4.10C The mapping shall demonstrate that all TSFIs trace to the behaviour described in the TOE design that they invoke.

ADV_TDS.4.1E The evaluator shall confirm that the information provided meets all requirements for content and presentation of evidence.

ADV_TDS.4.2E The evaluator shall determine that the design is an accurate and complete instantiation of all security functional requirements.

8.2.1.5 ADV_INT TSF internals

ADV_INT.2 Well-structured internals

ADV_INT.2.1D The developer shall design and implement the entire TSF such that it has well-structured internals.

ADV_INT.2.2D The developer shall provide an internals description and justification.

ADV_INT.2.1C The justification shall describe the characteristics used to judge the meaning of ``well-structured''.

ADV_INT.2.2C The TSF internals description shall demonstrate that the entire TSF is well-structured.

ADV_INT.2.1E The evaluator shall confirm that the information provided meets all requirements for content and presentation of evidence.

ADV_INT.2.2E The evaluator shall perform an internals analysis on the TSF.

8.2.2 AGD Guidance documents

8.2.2.1 AGD_OPE Operational user guidance

AGD_OPE.1 Operational user guidance

AGD_OPE.1.1D The developer shall provide operational user guidance.

AGD_OPE.1.1C The operational user guidance shall describe, for each user role, the user-accessible functions and privileges that should be controlled in a secure processing environment, including appropriate warnings.

AGD_OPE.1.2C The operational user guidance shall describe, for each user role, how to use the available interfaces provided by the TOE in a secure manner.

AGD_OPE.1.3C The operational user guidance shall describe, for each user role, the available functions and interfaces, in particular all security parameters under the control of the user, indicating secure values as appropriate.

AGD_OPE.1.4C The operational user guidance shall, for each user role, clearly present each type of security-relevant event relative to the user-accessible functions that need to be performed, including changing the security characteristics of entities under the control of the TSF.

AGD_OPE.1.5C The operational user guidance shall identify all possible modes of operation of the TOE (including operation following failure or operational error), their consequences and implications for maintaining secure operation.

AGD_OPE.1.6C The operational user guidance shall, for each user role, describe the security measures to be followed in order to fulfil the security objectives for the operational environment as described in the ST.

AGD_OPE.1.7C The operational user guidance shall be clear and reasonable.

AGD_OPE.1.1E The evaluator shall confirm that the information provided meets all requirements for content and presentation of evidence.

8.2.2.2 AGD_PRE Preparative procedures

AGD_PRE.1 Preparative procedures

AGD_PRE.1.1D The developer shall provide the TOE including its preparative procedures.

AGD_PRE.1.1C The preparative procedures shall describe all the steps necessary for secure acceptance of the delivered TOE in accordance with the developer's delivery procedures.

AGD_PRE.1.2C The preparative procedures shall describe all the steps necessary for secure installation of the TOE and for the secure preparation of the operational environment in accordance with the security objectives for the operational environment as described in the ST.

AGD_PRE.1.1E The evaluator shall confirm that the information provided meets all requirements for content and presentation of evidence.

AGD_PRE.1.2E The evaluator shall apply the preparative procedures to confirm that the TOE can be prepared securely for operation.

8.2.3 ALC Life-cycle support

8.2.3.1 ALC_CMC CM capabilities

ALC_CMC.4 Production support, acceptance procedures and automation

ALC_CMC.4.1D The developer shall provide the TOE and a reference for the TOE.

ALC_CMC.4.2D The developer shall provide the CM documentation.

ALC_CMC.4.3D The developer shall use a CM system.

ALC_CMC.4.1C The TOE shall be labelled with its unique reference.

ALC_CMC.4.2C The CM documentation shall describe the method used to uniquely identify the configuration items.

ALC_CMC.4.3C The CM system shall uniquely identify all configuration items.

ALC_CMC.4.4C The CM system shall provide automated measures such that only authorised changes are made to the configuration items.

ALC_CMC.4.5C The CM system shall support the production of the TOE by automated means.

ALC_CMC.4.6C The CM documentation shall include a CM plan.

ALC_CMC.4.7C The CM plan shall describe how the CM system is used for the development of the TOE.

ALC_CMC.4.8C The CM plan shall describe the procedures used to accept modified or newly created configuration items as part of the TOE.

ALC_CMC.4.9C The evidence shall demonstrate that all configuration items are being maintained under the CM system.

ALC_CMC.4.10C The evidence shall demonstrate that the CM system is being operated in accordance with the CM plan.

ALC_CMC.4.1E The evaluator shall confirm that the information provided meets all requirements for content and presentation of evidence.

8.2.3.2 ALC_CMS CM scope

ALC_CMS.5 Development tools CM coverage

ALC_CMS.5.1D The developer shall provide a configuration list for the TOE.

ALC_CMS.5.1C The configuration list shall include the following: the TOE itself; the evaluation evidence required by the SARs; the parts that comprise the TOE; the implementation representation; security flaw reports and resolution status; and development tools and related information.

ALC_CMS.5.2C The configuration list shall uniquely identify the configuration items.

ALC_CMS.5.3C For each TSF relevant configuration item, the configuration list shall indicate the developer of the item.

ALC_CMS.5.1E The evaluator shall confirm that the information provided meets all requirements for content and presentation of evidence.

8.2.3.3 ALC_DEL Delivery

ALC_DEL.1 Delivery procedures

ALC_DEL.1.1D The developer shall document and provide procedures for delivery of the TOE or parts of it to the consumer.

ALC_DEL.1.2D The developer shall use the delivery procedures.

ALC_DEL.1.1C The delivery documentation shall describe all procedures that are necessary to maintain security when distributing versions of the TOE to the consumer.

ALC_DEL.1.1E The evaluator shall confirm that the information provided meets all requirements for content and presentation of evidence.

8.2.3.4 ALC_DVS Development security

ALC_DVS.2 Sufficiency of security measures

ALC_DVS.2.1D The developer shall produce and provide development security documentation.

ALC_DVS.2.1C The development security documentation shall describe all the physical, procedural, personnel, and other security measures that are necessary to protect the confidentiality and integrity of the TOE design and implementation in its development environment.

ALC_DVS.2.2C The development security documentation shall justify that the security measures provide the necessary level of protection to maintain the confidentiality and integrity of the TOE.

ALC_DVS.2.1E The evaluator shall confirm that the information provided meets all requirements for content and presentation of evidence.

ALC_DVS.2.2E The evaluator shall confirm that the security measures are being applied.

8.2.3.5 ALC_LCD Life-cycle definition

ALC_LCD.1 Developer defined life-cycle model

ALC_LCD.1.1D The developer shall establish a life-cycle model to be used in the development and maintenance of the TOE.

ALC_LCD.1.2D The developer shall provide life-cycle definition documentation.

ALC_LCD.1.1C The life-cycle definition documentation shall describe the model used to develop and maintain the TOE.

ALC_LCD.1.2C The life-cycle model shall provide for the necessary control over the development and maintenance of the TOE.

ALC_LCD.1.1E The evaluator shall confirm that the information provided meets all requirements for content and presentation of evidence.

8.2.3.6 ALC_TAT Tools and techniques

ALC_TAT.2 Compliance with implementation standards

ALC_TAT.2.1D The developer shall provide the documentation identifying each development tool being used for the TOE.

ALC_TAT.2.2D The developer shall document and provide the selected implementation-dependent options of each development tool.

ALC_TAT.2.3D The developer shall describe and provide the implementation standards that are being applied by the developer.

ALC_TAT.2.1C Each development tool used for implementation shall be well-defined.

ALC_TAT.2.2C The documentation of each development tool shall unambiguously define the meaning of all statements as well as all conventions and directives used in the implementation.

ALC_TAT.2.3C The documentation of each development tool shall unambiguously define the meaning of all implementation-dependent options.

ALC_TAT.2.1E The evaluator shall confirm that the information provided meets all requirements for content and presentation of evidence.

ALC_TAT.2.2E The evaluator shall confirm that the implementation standards have been applied.

8.2.4 ASE Security Target evaluation

8.2.4.1 ASE_CCL Conformance claims

ASE_CCL.1 Conformance claims

ASE_CCL.1.1D The developer shall provide a conformance claim.

ASE_CCL.1.2D The developer shall provide a conformance claim rationale.

ASE_CCL.1.1C The conformance claim shall contain a CC conformance claim that identifies the version of the CC to which the ST and the TOE claim conformance.

ASE_CCL.1.2C The CC conformance claim shall describe the conformance of the ST to CC Part 2 as either CC Part 2 conformant or CC Part 2 extended.

ASE_CCL.1.3C The CC conformance claim shall describe the conformance of the ST to CC Part 3 as either CC Part 3 conformant or CC Part 3 extended.

ASE_CCL.1.4C The CC conformance claim shall be consistent with the extended components definition.

ASE_CCL.1.5C The conformance claim shall identify all PPs and security requirement packages to which the ST claims conformance.

ASE_CCL.1.6C The conformance claim shall describe any conformance of the ST to a package as either package-conformant or package-augmented.

ASE_CCL.1.7C The conformance claim rationale shall demonstrate that the TOE type is consistent with the TOE type in the PPs for which conformance is being claimed.

ASE_CCL.1.8C The conformance claim rationale shall demonstrate that the statement of the security problem definition is consistent with the statement of the security problem definition in the PPs for which conformance is being claimed.

ASE_CCL.1.9C The conformance claim rationale shall demonstrate that the statement of security objectives is consistent with the statement of security objectives in the PPs for which conformance is being claimed.

ASE_CCL.1.10C The conformance claim rationale shall demonstrate that the statement of security requirements is consistent with the statement of security requirements in the PPs for which conformance is being claimed.

ASE_CCL.1.1E The evaluator shall confirm that the information provided meets all requirements for content and presentation of evidence.

8.2.4.2 ASE_ECD Extended components definition

ASE_ECD.1 Extended components definition

ASE_ECD.1.1D The developer shall provide a statement of security requirements.

ASE_ECD.1.2D The developer shall provide an extended components definition.

ASE_ECD.1.1C The statement of security requirements shall identify all extended security requirements.

ASE_ECD.1.2C The extended components definition shall define an extended component for each extended security requirement.

ASE_ECD.1.3C The extended components definition shall describe how each extended component is related to the existing CC components, families, and classes.

ASE_ECD.1.4C The extended components definition shall use the existing CC components, families, classes, and methodology as a model for presentation.

ASE_ECD.1.5C The extended components shall consist of measurable and objective elements such that conformance or nonconformance to these elements can be demonstrated.

ASE_ECD.1.1E The evaluator shall confirm that the information provided meets all requirements for content and presentation of evidence.

ASE_ECD.1.2E The evaluator shall confirm that no extended component can be clearly expressed using existing components.

8.2.4.3 ASE_INT ST introduction

ASE_INT.1 ST introduction

ASE_INT.1.1D The developer shall provide an ST introduction.

ASE_INT.1.1C The ST introduction shall contain an ST reference, a TOE reference, a TOE overview and a TOE description.

ASE_INT.1.2C The ST reference shall uniquely identify the ST.

ASE_INT.1.3C The TOE reference shall identify the TOE.

ASE_INT.1.4C The TOE overview shall summarise the usage and major security features of the TOE.

ASE_INT.1.5C The TOE overview shall identify the TOE type.

ASE_INT.1.6C The TOE overview shall identify any non-TOE hardware/software/firmware required by the TOE.

ASE_INT.1.7C The TOE description shall describe the physical scope of the TOE.

ASE_INT.1.8C The TOE description shall describe the logical scope of the TOE.

ASE_INT.1.1E The evaluator shall confirm that the information provided meets all requirements for content and presentation of evidence.

ASE_INT.1.2E The evaluator shall confirm that the TOE reference, the TOE overview, and the TOE description are consistent with each other.

8.2.4.4 ASE_OBJ Security objectives

ASE_OBJ.2 Security objectives

ASE_OBJ.2.1D The developer shall provide a statement of security objectives.

ASE_OBJ.2.2D The developer shall provide a security objectives rationale.

ASE_OBJ.2.1C The statement of security objectives shall describe the security objectives for the TOE and the security objectives for the operational environment.

ASE_OBJ.2.2C The security objectives rationale shall trace each security objective for the TOE back to threats countered by that security objective and OSPs enforced by that security objective.

ASE_OBJ.2.3C The security objectives rationale shall trace each security objective for the operational environment back to threats countered by that security objective, OSPs enforced by that security objective, and assumptions upheld by that security objective.

ASE_OBJ.2.4C The security objectives rationale shall demonstrate that the security objectives counter all threats.

ASE_OBJ.2.5C The security objectives rationale shall demonstrate that the security objectives enforce all OSPs.

ASE_OBJ.2.6C The security objectives rationale shall demonstrate that the security objectives for the operational environment uphold all assumptions.

ASE_OBJ.2.1E The evaluator shall confirm that the information provided meets all requirements for content and presentation of evidence.

8.2.4.5 ASE_REQ Security requirements

ASE_REQ.2 Derived security requirements

ASE_REQ.2.1D The developer shall provide a statement of security requirements.

ASE_REQ.2.2D The developer shall provide a security requirements rationale.

ASE_REQ.2.1C The statement of security requirements shall describe the SFRs and the SARs.

ASE_REQ.2.2C All subjects, objects, operations, security attributes, external entities and other terms that are used in the SFRs and the SARs shall be defined.

ASE_REQ.2.3C The statement of security requirements shall identify all operations on the security requirements.

ASE_REQ.2.4C All operations shall be performed correctly.

ASE_REQ.2.5C Each dependency of the security requirements shall either be satisfied, or the security requirements rationale shall justify the dependency not being satisfied.

ASE_REQ.2.6C The security requirements rationale shall trace each SFR back to the security objectives for the TOE.

ASE_REQ.2.7C The security requirements rationale shall demonstrate that the SFRs meet all security objectives for the TOE.

ASE_REQ.2.8C The security requirements rationale shall explain why the SARs were chosen.

ASE_REQ.2.9C The statement of security requirements shall be internally consistent.

ASE_REQ.2.1E The evaluator shall confirm that the information provided meets all requirements for content and presentation of evidence.

8.2.4.6 ASE_SPD Security problem definition

ASE_SPD.1 Security problem definition

ASE_APD.1.1D The developer shall provide a security problem definition.

ASE_SPD.1.1C The security problem definition shall describe the threats.

ASE_SPD.1.2C All threats shall be described in terms of a threat agent, an asset, and an adverse action.

ASE_SPD.1.3C The security problem definition shall describe the OSPs.

ASE_SPD.1.4C The security problem definition shall describe the assumptions about the operational environment of the TOE.

ASE_SPD.1.1E The evaluator shall confirm that the information provided meets all requirements for content and presentation of evidence.

8.2.4.7 ASE_TSS TOE summary specification

ASE_TSS.1 TOE summary specification

ASE_TSS.1.1D The developer shall provide a TOE summary specification.

ASE_TSS.1.1C The TOE summary specification shall describe how the TOE meets each SFR.

ASE_TSS.1.1E The evaluator shall confirm that the information provided meets all requirements for content and presentation of evidence.

ASE_TSS.1.2E The evaluator shall confirm that the TOE summary specification is consistent with the TOE overview and the TOE description.

8.2.5 ATE Tests

8.2.5.1 ATE_COV Coverage

ATE_COV.2 Analysis of coverage

ATE_COV.2.1D The developer shall provide an analysis of the test coverage.

ATE_COV.2.1C The analysis of the test coverage shall demonstrate the correspondence between the tests in the test documentation and the TSFIs in the functional specification.

ATE_COV.2.2C The analysis of the test coverage shall demonstrate that all TSFIs in the functional specification have been tested.

ATE_COV.2.1E The evaluator shall confirm that the information provided meets all requirements for content and presentation of evidence.

8.2.5.2 ATE_DPT Depth

ATE_DPT.3 Testing: modular design

ATE_DPT.3.1D The developer shall provide the analysis of the depth of testing.

ATE_DPT.3.1C The analysis of the depth of testing shall demonstrate the correspondence between the tests in the test documentation and the TSF subsystems and modules in the TOE design.

ATE_DPT.3.2C The analysis of the depth of testing shall demonstrate that all TSF subsystems in the TOE design have been tested.

ATE_DPT.3.3C The analysis of the depth of testing shall demonstrate that all TSF modules in the TOE design have been tested.

ATE_DPT.3.1E The evaluator shall confirm that the information provided meets all requirements for content and presentation of evidence.

8.2.5.3 ATE_FUN Functional tests

ATE_FUN.1 Functional testing

ATE_FUN.1.1D The developer shall test the TSF and document the results.

ATE_FUN.1.2D The developer shall provide test documentation.

ATE_FUN.1.1C The test documentation shall consist of test plans, expected test results and actual test results.

ATE_FUN.1.2C The test plans shall identify the tests to be performed and describe the scenarios for performing each test. These scenarios shall include any ordering dependencies on the results of other tests.

ATE_FUN.1.3C The expected test results shall show the anticipated outputs from a successful execution of the tests.

ATE_FUN.1.4C The actual test results shall be consistent with the expected test results.

ATE_FUN.1.1E The evaluator shall confirm that the information provided meets all requirements for content and presentation of evidence.

8.2.5.4 ATE_IND Independent testing

ATE_IND.2 Independent testing - sample

ATE_IND.2.1D The developer shall provide the TOE for testing.

ATE_IND.2.1C The TOE shall be suitable for testing.

ATE_IND.2.2C The developer shall provide an equivalent set of resources to those that were used in the developer's functional testing of the TSF.

ATE_IND.2.1E The evaluator shall confirm that the information provided meets all requirements for content and presentation of evidence.

ATE_IND.2.2E The evaluator shall execute a sample of tests in the test documentation to verify the developer test results.

ATE_IND.2.3E The evaluator shall test a subset of the TSF to confirm that the TSF operates as specified.

8.2.6 AVA Vulnerability assessment

8.2.6.1 AVA_VAN Vulnerability analysis

AVA_VAN.5 Advanced methodical vulnerability analysis

AVA_VAN.5.1D The developer shall provide the TOE for testing.

AVA_VAN.5.1C The TOE shall be suitable for testing.

AVA_VAN.5.1E The evaluator shall confirm that the information provided meets all requirements for content and presentation of evidence.

AVA_VAN.5.2E The evaluator shall perform a search of public domain sources to identify potential vulnerabilities in the TOE.

AVA_VAN.5.3E The evaluator shall perform an independent, methodical vulnerability analysis of the TOE using the guidance documentation, functional specification, TOE design, security architecture description and implementation representation to identify potential vulnerabilities in the TOE.

AVA_VAN.5.4E The evaluator shall conduct penetration testing based on the identified potential vulnerabilities to determine that the TOE is resistant to attacks performed by an attacker possessing High attack potential.

8.3 Security Requirements Rationale

8.3.1 Objectives

8.3.1.1 Security Objectives for the TOE

Security Objectives drawn from the Protection Profiles

OT.Lifecycle_Security is provided by the SFR as follows. The SCD import is controlled by TSF according to FDP_ACC.1/SCD_Import, FDP_ACF.1/SCD_Import and FDP_ITC.1/SCD. The confidentiality of the SCD is protected during import according to FDP_UCT.1/SCD in the trusted channel FDP_ITC.1/SCD.

Secure SCD/SVD generation is ensured by FCS_CKM.1/SCD/SVD_Generation. The SCD/SVD generation is controlled by TSF according to FDP_ACC.1/SCD/SVD_Generation and FDP_ACF.1/SCD/SVD_Generation. The SVD transfer for certificate generation is controlled by TSF according to FDP_ACC.1/SVD_Transfer and FDP_ACF.1/SVD_Transfer.

The secure SCD usage is ensured cryptographically according to FCS_COP.1/Sign. The SCD usage is controlled by access control FDP_ACC.1/Signature_Creation, FDP_ACF.1/Signature_Creation which is based on the security attribute secure TSF management according to FMT_MOF.1, FMT_MSA.1/Admin, FMT_MSA.1/Signatory, FMT_MSA.2, FMT_MSA.3, FMT_MSA.4, FMT_MTD.1/Admin, FMT_MTD.1/Signatory, FMT_MTD.1/UnblockChange_RAD, FMT_MTD.1/Erase_PIN, FMT_SMF.1 and FMT_SMR.1. The test functions FPT_TST.1 provides failure detection throughout the lifecycle.

The SFR FCS_CKM.4, ensures a secure SCD destruction.

OT.SCD/SVD_Auth_Gen addresses that generation of a SCD/SVD pair requires proper user authentication. The TSF specified by FIA_UID.1 and FIA_UAU.1 provide user identification and user authentication prior to enabling access to authorized functions. The SFR FDP_ACC.1/SCD/SVD_Generation and FDP_ACF.1/SCD/SVD_Generation provide access control for the SCD/SVD generation. The security attributes of the authenticated user are provided by FMT_MSA.1/Admin, FMT_MSA.2, and FMT_MSA.3 for static attribute initialisation. The SFR FMT_MSA.4 defines rules for inheritance of the security attribute "SCD operational" of the SCD.

OT.SCD_Unique implements the requirement of practically unique SCD as laid down in Annex III, paragraph 1(a), which is provided by the cryptographic algorithms specified by FCS_CKM.1/SCD/SVD_Generation.

OT.SCD_SVD_Corresp addresses that the SVD corresponds to the SCD implemented by the TOE. This is provided by the algorithms specified by FCS_CKM.1/SCD/SVD_Generation to generate corresponding SVD/SCD pairs. The security functions specified by FDP_SDI.2/Persistent ensure that the keys are not modified, so to retain the correspondence. Moreover, the SCD Identifier allows the environment to identify the SCD and to link it with the appropriate SVD. The management functions identified by FMT_SMF.1 and by FMT_MSA.4 allow R.Admin to modify the default value of the security attribute SCD Identifier.

OT.SCD_Auth_Imp is provided by the security functions specified by the following SFR. FIA_UID.1 and FIA_UAU.1 ensure that the user is identified and authenticated before SCD can be imported. FDP_ACC.1/SCD_Import and FDP_ACF.1/SCD_Import ensure that only authorised users can import SCD.

OT.SCD_Secrecy is provided by the security functions specified by the following SFR. FDP_UCT.1/SCD and FDP_ITC.1/SCD ensures the confidentiality for SCD import.

FCS_CKM.1/SCD/SVD_Generation ensures the use of secure cryptographic algorithms for SCD/SVD generation. Cryptographic quality of SCD/SVD pair shall prevent disclosure of SCD by cryptographic attacks using the publicly known SVD.

The security functions specified by FDP_RIP.1 and FCS_CKM.4 ensure that residual information on SCD is destroyed after the SCD has been used for signature creation and that destruction of SCD leaves no residual information.

The security functions specified by FDP_SDI.2/Persistent ensure that no critical data is modified which could alter the efficiency of the security functions or leak information of the SCD. FPT_TST.1 tests the working conditions of the TOE and FPT_FLS.1 guarantees a secure state when integrity is violated and thus assures that the specified security functions are operational. An example where compromising error conditions are countered by FPT_FLS.1 is fault injection for differential fault analysis (DFA). SFR FPT_EMS.1 and FPT_PHP.3 require additional security features of the TOE to ensure the confidentiality of the SCD.

OT.Sig_Secure is provided by the cryptographic algorithms specified by FCS_COP.1/Sign, which ensures the cryptographic robustness of the signature algorithms. FDP_SDI.2/Persistent corresponds to the integrity of the SCD implemented by the TOE and FPT_TST.1 ensures self-tests ensuring correct signature creation.

OT.Sigy_SigF is provided by an SFR for identification authentication and access control. FIA_UAU.1 and FIA_UID.1 ensure that no signature creation function can be invoked before the signatory is identified and authenticated.

The security functions specified by FMT_MTD.1/Admin and FMT_MTD.1/Signatory manage the authentication function. SFR FIA_AFL.1/RAD provides protection against a number of attacks, such as cryptographic extraction of residual information, or brute force attacks against authentication.

The security function specified by FDP_SDI.2/DTBS ensures the integrity of stored DTBS. The security functions specified by FDP_ACC.1/Signature_Creation and FDP_ACF.1/Signature_Creation provide access control based on the security attributes managed according to the SFR FMT_MTD.1/Signatory, FMT_MSA.2, FMT_MSA.3 and FMT_MSA.4. The SFR FMT_SMF.1 and FMT_SMR.1 list these management functions and the roles. These ensure that the signature process is restricted to the signatory. FMT_MOF.1 restricts the ability to enable the signature creation function to the signatory. FMT_MSA.1/Signatory restricts the ability to modify the security attributes SCD operational to the signatory. Furthermore, FDP_RIP.1 prevents misuse of any resources containing the SCD after de-allocation (e.g. after the signature creation process) and ensures that no attacker can get hold of the SCD (to create signatures outside the TOE) once SCD has been deleted by the legitimate signatory. FMT_MTD.1/Unblock_PIN and FMT_MTD.1/UnblockChange_RAD ensure the unblocking of the PIN (including the RAD) is made under the sole control of the administrator. In phase 6, the RAD may be loaded on the TOE by the Personalization Agent as defined in FMT_SMF.1. The Personalization Agent is authenticated with a mutual authentication performed with FCS_RND.1 and FCS_COP.1/GP, and is authenticated with FMT_SMR.1. During the mutual authentication, a session encryption key is agreed between the TOE and the Personalization Agent and used by the TOE to decrypt the RAD using FCS_COP.1/GP Secret Data Protection, ensuring the confidentiality of the RAD during its transfer in phase 6. In phase 6, FMT_MSA.1/ Signatory guarantees that the Personalization Agent cannot sign on behalf of the signatory, ensuring the signature creation features remains under the sole control of the signatory.

OT.DTBS_Integrity_TOE ensures that the DTBS/R is not altered by the TOE. The integrity functions specified by FDP_SDI.2/DTBS require that the DTBS/R has not been altered by the TOE.

OT.EMSEC_Design covers that no intelligible information is emanated. This is provided by FPT_EMS.1.1 and FPT_EMS.1/PIN-PUK-KEYS.

OT.Tamper_ID is provided by FPT_PHP.1 by the means of passive detection of physical attacks.

OT.Tamper_Resistance is provided by FPT_PHP.3 to resist physical attacks.

OT.TOE_SSCD_Auth requires the TOE to provide security mechanisms to identify and to authenticate themselves as SSCD, which is directly provided by FIA_API.1 (Authentication proof of identity). The SFR FIA_UAU.1 allows establishment of the trusted channel before (human) user is authenticated.

OT.TOE_TC_SVD_Exp requires the TOE to provide a trusted channel to the CGA to protect the integrity of the SVD exported to the CGA, which is directly provided by

The SVD transfer for certificate generation is controlled by TSF according to FDP_ACC.1/SVD_Transfer and FDP_ACF.1/SVD_Transfer

FDP_DAU.2/SVD (Data authentication with identity of guarantor), which requires the TOE to provide CGA with the ability to verify evidence of the validity of the SVD and the identity of the user that generated the evidence.

FTP_ITC.1/SVD (inter-TSF trusted channel), which requires the TOE to provide a trusted channel to the CGA.

Additional Security Objectives for the TOE

OT.Authentication_Secure is provided by FCS_RND.1 and FCS_COP.1/GP for the authentication of the Personalization agent.

The use of a challenge freshly generated by the TOE with FCS_RND.1 in these authentication protocols ensures a protection against replay attacks when authenticating external entities. The security function specified by FPT_TST.1 ensures that the security functions are performed correctly and FDP_SDI.2/Persistent guarantees the integrity of the authentication key(s) used by the TOE. FMT_SMR.1 and FMT_SMF.1 ensure the TOE can distinguish between external entities successfully authenticated (R.Admin) and can grant them dedicated rights. In case of authentication protocols involving the import of ephemeral public key on the TOE (using Card verifiable certificates), FDP_RIP.1 ensures that the key value is not kept by the TOE after usage and then can not be reused for a replay attack.

This objective ensures as well the establishment of a trusted channel following a successful mutual authentication. This trusted channel ensures authenticity, integrity and confidentiality of communication. FCS_CKM.1/Session Keys generate session keys for the secure communication from a common secret agreed between the TOE and the external entity during the mutual authentication procedure.

Any incoming command shall contain a MAC computed by the issuer with the session key agreed during the mutual authentication, so that any unauthenticated or non integer command is detected by the MAC verification performed by the TOE using FCS_COP.1/SM in Integrity. The data exchanged through this trusted channel are also protected in confidentiality thanks to FCS_COP.1/SM in Confidentiality, ensuring they can only be disclosed to the parties authenticated during the mutual authentication step. The encryption key is ephemeral as it is generated during the mutual authentication using a challenge freshly generated by the TOE using FCS_RND.1, which ensures that dictionary attacks cannot be performed on encrypted data. When an integrity error is detected, or if the MAC is wrong (wrong authentication of the command issuer), the session keys (for integrity and confidentiality) are erased thanks to FCS_CKM.4 so that they cannot be reused anymore, causing the trusted channel to be irreversibly lost. In particular, it ensures that encrypted data that may be caught by an attacker cannot be reused anymore to masquerade the TOE.

In phase 6, the integrity and confidentiality of data is ensured by FCS_COP.1/GP Secret Data Protection.

The SSCD provides a proof of identity with FIA_API.1.

This objective ensures as well that any authentication key is loaded in the TOE by an authenticated user, so that only genuine keys associated to genuine users are declared to the TOE. The key import defined by FMT_SMF.1 is protected by access control. It is protected by the proper Agent(s) authentication that cannot be bypassed to access these functions with the TSF specified by FIA_UID.1 and FIA_UAU.1. The agent entitled to load the authentication key is (are) authenticated with FMT_SMR.1. Effort to bypass the access control by a frontal exhaustive attack is blocked by FIA_AFL.1/RAD.

This objective ensures the verification of the authenticity of the TOE as a whole device. This objective is mainly achieved by FIA_API.1/TOE Authentication using FCS_CKM.1/DH_PACE. CA provides an evidence of possessing the Chip Authentication Private Key (CAPK). FMT_MTD.1/CAPK governs creating/loading CAPK, whereas FMT_MTD.1/KEY_READ requires making this key unreadable by users. Hence, its value remains confidential. FDP_RIP.1 requires erasing the values of CAPK and the session keys, here for CMAC. The authentication token is calculated using FCS_COP.1/SM in Integrity. The TOE holder provides a proof of identity with FIA_API.1/TOE Authentication.

This objective aims to explicitly protect sensitive (as opposed to common) user and TSF-Data. This is mainly achieved by enforcing (FDP_UCT.1/TRM and FDP_UIT.1/TRM) the access control SFPs FDP_ACC.1/TRM and FDP_ACF.1/TRM. A specific authorization level is achieved by terminal identification/authentication as required by the SFRs FIA_UID.1/PACE, FIA_UAU.1/PACE supported by FCS_COP.1/SIG_VER. The TA protocol uses the result of the PACE authentication (FIA_UID.1/PACE, FIA_UAU.1/PACE, confidentiality of the PACE passwords is ensured by FMT_MTD.1/KEY_READ) being, in turn, supported by FCS_CKM.1/DH_PACE. Since PACE can use the PIN as the shared secret, the use and management of the PIN (FIA_AFL.1/AUTH, FMT_MTD.1/Resume_PIN, FMT_MTD.1/Unblock_PIN, FMT_MTD.1/Initialize_PIN, FMT_MTD.1/Change_PIN, FMT_MTD.1/UnblockChange_RAD, FMT_MTD.1/Erase_PIN, FMT_MTD.1/Reinitialize_PIN, FMT_MTD.1/UnblockChange_PUK) also support to achieve this objective. FDP_RIP.1 requires erasing the temporal values of the PIN and PUK. FIA_UAU.4/PACE, FIA_UAU.5/PACE, FIA_UAU.6/PACE and FCS_CKM.4 represent some specific properties of the used protocols. To allow for a verification of the certificate chain as required in FMT_MTD.3, the CVCA's public key and certificate as well as the current date are written or updated by authorized identified role as required by FMT_MTD.1/CVCA_INI, FMT_MTD.1/CVCA_UPD and FMT_MTD.1/DATE. In contactless, this objective for the data exchanged is mainly achieved by FTP_ITC.1/PACE using FCS_COP.1/SM in Confidentiality. A prerequisite for establishing this trusted channel is a successful Chip Authentication, cf. FIA_API.1/TOE Authentication using FCS_CKM.1/DH_PACE and possessing the special properties FIA_UAU.5/PACE, and FIA_UAU.6/EAC. As a prerequisite of this trusted channel, a trusted channel is established with the PACE protocol using FIA_UID.1/PACE, FIA_UAU.1/PACE and FCS_CKM.1/DH_PACE and possessing the special properties FIA_UAU.5/PACE, FIA_UAU.6/PACE. CA provides an evidence of possessing the Chip Authentication Private Key (CAPK). FMT_MTD.1/CAPK governs creating/loading CAPK, FMT_MTD.1/KEY_READ requires making this key unreadable by users. Thus its value remains confidential. FDP_RIP.1 requires erasing the values of CAPK and session keys, here for KENC. The SFRs FMT_SMF.1 and FMT_SMR.1/PACE support the related functions and roles.

This objective ensures also the authenticity of user- and TSF-Data (after Terminal- and the Chip Authentication) by enabling its verification on both the terminal-side and by an active verification by the TOE itself. This objective is mainly achieved by FTP_ITC.1/PACE in contactless using FCS_COP.1/SM in Integrity. A prerequisite for establishing this trusted channel is a successful Chip Authentication, cf. FIA_API.1/TOE Authentication using FCS_CKM.1/DH_PACE and possessing the special properties FIA_UAU.5/PACE, and FIA_UAU.6/EAC. As a prerequisite of this trusted channel, a trusted channel is established with the PACE protocol using FIA_UID.1/PACE, FIA_UAU.1/PACE and FCS_CKM.1/DH_PACE and possessing the special properties FIA_UAU.5/PACE, FIA_UAU.6/PACE. CA provides an evidence of possessing the Chip Authentication Private Key (CAPK). FMT_MTD.1/CAPK governs creating/loading CAPK, FMT_MTD.1/KEY_READ requires to make this key unreadable by users. Hence its value remains confidential. FDP_RIP.1 requires to erase the values of CAPK and session keys, here for KMAC. A prerequisite for successful CA is an accomplished TA as required by FIA_UID.1/PACE, FIA_UAU.1/PACE supported by FCS_COP.1/SIG_VER. The TA protocol uses the result of the PACE authentication (FIA_UID.1/PACE, FIA_UAU.1/PACE) being, in turn, supported by FCS_CKM.1/DH_PACE. Since PACE can use the PIN as the shared secret, the use and management of the PIN (FIA_AFL.1/AUTH, FMT_MTD.1/Resume_PIN, FMT_MTD.1/Initialize_PIN, FMT_MTD.1/Change_PIN, FMT_MTD.1/Unblock_PIN, FMT_MTD.1/UnblockChange_RAD, FMT_MTD.1/Erase_PIN, FMT_MTD.1/Reinitialize_PIN, FMT_MTD.1/UnblockChange_PUK) also support achieving this objective. FDP_RIP.1 requires to erase the temporal values of the PIN and PUK. FIA_UAU.4/PACE, FIA_UAU.5/PACE, FIA_UAU.6/EAC and FCS_CKM.4 represent some specific required properties of the used protocols. To allow for a verification of the certificate chain as required in FMT_MTD.3, the CVCA's public key and certificate, as well as the current date, are written or updated by authorized identified roles as required by FMT_MTD.1/CVCA_INI, FMT_MTD.1/CVCA_UPD and FMT_MTD.1/DATE. The SFRs FMT_SMF.1 and FMT_SMR.1/PACE support the related functions and roles. This objective ensures the confidentiality of the user- and TSF-Data stored and, after Terminal- and Chip Authentication, of their exchange. This objective for the data stored is mainly achieved by FDP_ACC.1/TRM and FDP_ACF.1/TRM. Enforcement of the two previous in a protected manner is ensured by FDP_UCT.1/TRM and FDP_UIT.1/TRM. A specific authorization level is achieved by terminal identification/authentication as required by the SFRs FIA_UID.1/PACE, FIA_UAU.1/PACE

supported by FCS_COP.1/SIG_VER. The TA protocol uses the result of the PACE authentication (FIA_UID.1/PACE, FIA_UAU.1/PACE, confidentiality of the PACE passwords is ensured by FMT_MTD.1/KEY_READ) being, in turn, supported by FCS_CKM.1/DH_PACE. Since PACE can use the PIN as the shared secret, the use and management of the PIN (FIA_AFL.1/AUTH, FMT_MTD.1/Resume_PIN, FMT_MTD.1/Unblock_PIN, FMT_MTD.1/Change_PIN, FMT_MTD.1/Initialize_PIN, FMT_MTD.1/UnblockChange_RAD, FMT_MTD.1/Erase_PIN, FMT_MTD.1/Reinitialize_PIN, FMT_MTD.1/UnblockChange_PUK) also support to achieve this objective. FDP_RIP.1 requires erasing the temporal values of the PIN and PUK. FIA_UAU.4/PACE, FIA_UAU.5/PACE, FIA_UAU.6/PACE and FCS_CKM.4 represent some specific properties of the used protocols. To allow for a verification of the certificate chain as required in FMT_MTD.3, the CVCA's public key and certificate as well as the current date are written or updated by authorized identified role as required by FMT_MTD.1/CVCA_INI, FMT_MTD.1/CVCA_UPD and FMT_MTD.1/DATE. This objective for the data exchanged is mainly achieved in contactless by FTP_ITC.1/PACE using FCS_COP.1/SM in Confidentiality. A prerequisite for establishing this trusted channel is a successful Chip Authentication, cf. FIA_API.1/TOE Authentication using FCS_CKM.1/DH_PACE and possessing the special properties FIA_UAU.5/PACE, and FIA_UAU.6/EAC. As a prerequisite of this trusted channel, a trusted channel is established with the PACE protocol using FIA_UID.1/PACE, FIA_UAU.1/PACE and FCS_CKM.1/DH_PACE and possessing the special properties FIA_UAU.5/PACE, FIA_UAU.6/PACE. CA provides an evidence of possessing the Chip Authentication Private Key (CAPK). FMT_MTD.1/CAPK governs creating/loading CAPK, FMT_MTD.1/KEY_READ requires making this key unreadable by users. Thus its value remains confidential. FDP_RIP.1 requires erasing the values of CAPK and session keys, here for KENC. The SFRs FMT_SMF.1 and FMT_SMR.1/PACE support the related functions and roles. This objective ensures the integrity of stored user- and TSF-Data and, after Terminal- and Chip Authentication, of these data exchanged (physical manipulation and unauthorized modifying). Physical manipulation is addressed by FPT_PHP.3. Unauthorized modifying of the stored data is addressed by FDP_ACC.1/TRM and FDP_ACF.1/TRM. Enforcement of the two previous in a protected manner is ensured by FDP_UCT.1/TRM and FDP_UIT.1/TRM. A specific authorization level is achieved by terminal identification/ authentication as required by the SFRs FIA_UID.1/PACE, FIA_UAU.1/PACE supported by FCS_COP.1/SIG_VER. The TA protocol uses the result of PACE authentication (FIA_UID.1/PACE, FIA_UAU.1/PACE) being, in turn, supported by FCS_CKM.1.1/DH_PACE. Since PACE can use the PIN as the shared secret, using and management of PIN (FIA_AFL.1/AUTH, FMT_MTD.1/Resume_PIN, FMT_MTD.1/Change_PIN, FMT_MTD.1/Unblock_PIN, FMT_MTD.1/Initialize_PIN, FMT_MTD.1/UnblockChange_RAD, FMT_MTD.1/Erase_PIN, FMT_MTD.1/Reinitialize_PIN, FMT_MTD.1/UnblockChange_PUK) also support achievement of this objective. FDP_RIP.1 requires erasing the temporal values of PIN, PUK. FIA_UAU.4/PACE, FIA_UAU.5/PACE and FCS_CKM.4 represent some required specific properties of the used protocols. To allow for a verification of the certificate chain as required in FMT_MTD.3, the CVCA's public key and certificate as well as the current date are written or update by authorized identified role as required by FMT_MTD.1/CVCA_INI, FMT_MTD.1/CVCA_UPD and FMT_MTD.1/DATE. Unauthorized modifying of the exchanged data is addressed by FTP_ITC.1/PACE in contactless using FCS_COP.1/SM in integrity. A prerequisite for establishing this trusted channel is a successful Chip Authentication, cf. FIA_API.1/TOE Authentication using FCS_CKM.1/DH_PACE possessing the special properties FIA_UAU.5/PACE and FIA_UAU.6/EAC. As a prerequisite of this trusted channel a trusted channel established with the PACE protocol using FIA_UID.1/PACE, FIA_UAU.1/PACE and FCS_CKM.1/DH_PACE and possessing the special properties FIA_UAU.5/PACE, FIA_UAU.6/PACE. CA provides an evidence of possessing the Chip Authentication Private Key (CAPK). FMT_MTD.1/CAPK governs creating/loading CAPK, and FMT_MTD.1/KEY_READ requires CAPK to be unreadable by users; thus its value remains confidential. FDP_RIP.1 requires erasing the values of CAPK and session keys (here: for KMAC). The SFRs FMT_SMF.1 and FMT_SMR.1/PACE support related functions and roles. This objective prevents TOE's functions being not intended to be used in the operational phase from manipulating and disclosing the User- and TSF-data. This objective is achieved by FMT_LIM.1 and FMT_LIM.2 preventing misuse of test and other functionality of the TOE having not to be used in the TOE's operational life cycle phase. This objective protects against disclosure of confidential User- or/and TSF-data stored on / processed by the TOE. This objective is achieved

by FPT_EMS.1 and FPT_EMS.1/PIN-PUK-KEYS for measurement and analysis of the shape and amplitude of signals or the time between events found by measuring signals on the electromagnetic field, power consumption, clock, or I/O lines,

by FPT_FLS.1 and FPT_TST.1 for forcing a malfunction of the TOE, and

by FPT_PHP.3 for a physical manipulation of the TOE.

This objective ensures a correct operation of the TOE by preventing its operation outside the normal operating conditions. This objective is covered by FPT_TST.1 requiring self tests to demonstrate the correct operation of the TOE and tests of authorised users to verify the integrity of the TSF-data and the embedded software (TSF code) as well as by FPT_FLS.1 requiring entering a secure state of the TOE in case of detected failure or operating conditions possibly causing a malfunction.

This objective protects of the confidentiality and integrity of the User- and TSF-data as well as embedded software stored in the TOE. This objective is completely covered by FPT_PHP.3 in an obvious way.

OT.Key_Lifecycle_Security Secure Keys generation is ensured by FCS_CKM.1/SCD/SVD_Generation.

The secure keys usage is ensured cryptographically according to FCS_COP.1/Digital Auth, FCS_COP.1/Enc Key Decipherment. Keys usage is based on the security attribute secure TSF management according to FMT_MSA.2, FMT_MSA.3, FMT_SMF.1 and FMT_SMR.1. The test functions FPT_TST.1 provides failure detection throughout the lifecycle.

The SFR FCS_CKM.4 ensures a secure keys destruction.

OT.Keys_Secrecy is provided by the security functions specified by the following SFR.

FCS_CKM.1/SCD/SVD_Generation ensure the use of secure cryptographic algorithms for keys generation. Cryptographic quality of the asymmetric key pair(s) shall prevent disclosure of the TOE's private authentication key(s) and eServices key(s) by cryptographic attacks using the publicly known public key. The security functions specified by FDP_RIP.1 and FCS_CKM.4 ensure that residual information on a key(s) is destroyed after a key has been used for authentication (verification or proof) or an eServices keys has been used and that destruction of key(s) leaves no residual information.

The security functions specified by FDP_SDI.2/Persistent ensure that no critical data is modified which could alter the efficiency of the security functions or leak information of the authentication key.

FPT_TST.1 tests the working conditions of the TOE and FPT_FLS.1 guarantees a secure state when integrity is violated and thus assures that the specified security functions are operational. An example where compromising error conditions are countered by FPT_FLS.1 is fault injection for differential fault analysis (DFA).

FPT_EMS.1/PIN-PUK-KEYS and FPT_PHP.3 require additional security features of the TOE to ensure the confidentiality of the key(s).

OT.TOE_AuthKey_Unique implements the requirement of practically unique TOE's authentication private key, which is provided by the cryptographic algorithms specified by FCS_CKM.1/SCD/SVD_Generation.

OT.Lifecycle_Management ensures a correct separation of the TOE life cycle between phase 6 and 7.

In phase 6, FMT_MTD.1/TOE State ensures the TOE irreversibly switches from phase 6 to phase 7 under the sole control of the Personalization Agent. The Personalization Agent is authenticated with a mutual authentication performed with FCS_RND.1 and FCS_COP.1/GP Secret Data Protection and is authenticated with FMT_SMR.1.

In phase 7, FDP_ACC.1/Signature_Creation, FDP_ACC.1/SVD_Transfer, FDP_ACC.1/SCD/SVD_Generation, FDP_ACC.1/SCD_Import, FDP_ACF.1/Signature_Creation, FDP_ACF.1/SVD_Transfer, FDP_ACF.1/SCD/SVD_Generation, FDP_ACF.1/SCD_Import, FMT_MTD.1/Unblock_PIN, FMT_MTD.1/UnblockChange_RAD, FMT_MTD.1/Erased_PIN, FMT_MOF.1, FMT_MTD.1/Admin, FMT_MTD.1/Signatory ensures the Personalization Agent does not control the TOE anymore. In phase 6, the Personalization Agent has complete control over the administrative functions of the TOE. It may import, erase, generate SCD/SVD, export SVD, manage Keys, create RAD and manage the configuration of the TOE as mandated in FMT_SMF.1, according to the security policies defined in FDP_ACC.1/SVD transfer, FDP_ACC.1/SCD/SVD_Generation, FDP_ACC.1/SCD import, FDP_ACF.1/SVD transfer, FDP_ACF.1/SCD/SVD_Generation, FDP_ACF.1/SCD import, It may as

well change TOE State (FMT_MTD.1/TOE State). These functions are protected by the Personalization Agent authentication that cannot be bypassed to access these functions with the TSF specified by FIA_UID.1 and FIA_UAU.1. FMT_MSA.1/Admin, FMT_MSA.2, FMT_MSA.3 ensure that the sole Personalization Agent can realize these functions.

OT.eServices is provided by the cryptographic mechanisms specified by (1) FCS_COP.1/Digital Auth, (2) FCS_COP.1/Enc Key Decipherment. These requirements ensure the cryptographic robustness of these eServices. The eServices keys may be loaded, generated, and the matching public key may be exported as required by FMT_SMF.1 and FMT_SMR.1. These functions are protected by the proper Agent(s) authentication that cannot be bypassed to access these functions with the TSF specified by FIA_UID.1 and FIA_UAU.1. Effort to bypass the access control by a frontal exhaustive attack is blocked by FIA_AFL.1/RAD.

OT.AC_Pers_EAC ensures that only the personalization agent can write user- and TSF-Data into the TOE, and that some of this data cannot be altered after personalization. This property is covered by FDP_ACC.1/TRM and FDP_ACF.1/TRM requiring, amongst other, an appropriate authorization level of an Authentication Terminal. This authorization level can be achieved by terminal identification/authentication as required by the SFRs FIA_UID.1/PACE and FIA_UAU.1/PACE. The SFRs FMT_SMF.1 and FMT_SMR.1/PACE support the related functions and roles. Since only an Authentication Terminal can reach the necessary authorization level, using and managing the PIN (the related SFRs are FIA_AFL.1/AUTH, FMT_MTD.1/Resume_PIN, FMT_MTD.1/Change_PIN, FMT_MTD.1/Unblock_PIN, FMT_MTD.1/Initialize_PIN, FMT_MTD.1/UnblockChange_RAD, FMT_MTD.1/Erase_PIN, FMT_MTD.1/Reinitialize_PIN, FMT_MTD.1/UnblockChange_PUK) also support the achievement of this objective. FDP_RIP.1 requires erasing the temporal values PIN and PUK.

Finally, FMT_MTD.1/KEY_READ ensures that cryptographic keys for EAC cannot be read by users. **OT.Tracing** ensures that the TOE prevents gathering TOE tracing data by means of unambiguously identifying the electronic document remotely through establishing or listening to communication via the contactless-based interface of the TOE without a priori knowledge of the correct values of shared passwords (CAN, PIN, PUK). This objective is achieved by FIA_AFL.1/AUTH and FTP_ITC.1/PACE.

8.3.2 Rationale tables of Security Objectives and SFRs

Security Objectives	Security Functional Requirements	Rationale
OT.Lifecycle_Security	FCS_CKM.1/SCD/SVD_Generation, FCS_CKM.4, FDP_ACC.1/SCD/SVD_Generation, FDP_ACF.1/SCD/SVD_Generation, FDP_ACC.1/SVD_Transfer, FDP_ACF.1/Signature_Creation, FDP_ACC.1/Signature_Creation, FDP_ACF.1/SVD_Transfer, FMT_MOF.1, FMT_MSA.1/Admin, FMT_MSA.1/Signatory, FMT_MSA.2, FMT_MSA.3, FMT_MSA.4, FMT_MTD.1/Admin, FMT_MTD.1/Signatory, FMT_SMR.1, FMT_SMF.1, FMT_TST.1, FCS_COP.1/Sign, FDP_ACC.1/SCD_Import, FDP_ACF.1/SCD_Import, FDP_ITC.1/SCD, FDP_UCT.1/SCD, FTP_ITC.1/SCD, FMT_MTD.1/UnblockChange_RAD, FMT_MTD.1/Erase_PIN	Section 8.3.1
OT.SCD/SVD_Auth_Gen	FDP_ACC.1/SCD/SVD_Generation, FDP_ACF.1/SCD/SVD_Generation, FIA_UAU.1, FIA_UID.1, FMT_MSA.1/Admin, FMT_MSA.2, FMT_MSA.3, FMT_MSA.4	Section 8.3.1
OT.SCD_Unique	FCS_CKM.1/SCD/SVD_Generation	Section 8.3.1

OT.SCD_SVD_Corresp	FCS_CKM.1/SCD/SVD_Generation, FDP_SDI.2/Persistent, FMT_MSA.4, FMT_SMF.1	Section 8.3.1
OT.SCD_Auth_Imp	FIA_UID.1, FIA_UAU.1, FDP_ACC.1/SCD_Import, FDP_ACF.1/SCD_Import	Section 8.3.1
OT.SCD_Secrecy	FCS_CKM.1/SCD/SVD_Generation, FCS_CKM.4, FDP_RIP.1, FDP_SDI.2/Persistent, FPT_FLS.1, FPT_PHP.3, FPT_TST.1, FPT_EMS.1, FDP_UCT.1/SCD, FTP_ITC.1/SCD	Section 8.3.1
OT.Sig_Secure	FDP_SDI.2/Persistent, FPT_TST.1, FCS_COP.1/Sign	Section 8.3.1
OT.Sigy_SigF	FDP_ACF.1/Signature_Creation, FDP_ACC.1/Signature_Creation, FDP_RIP.1, FDP_SDI.2/DTBS, FIA_AFL.1/RAD, FIA_UAU.1, FIA_UID.1, FMT_MOF.1, FMT_MSA.1/Signatory, FMT_MSA.2, FMT_MSA.3, FMT_MSA.4, FMT_MTD.1/Admin, FMT_MTD.1/Signatory, FMT_SMR.1, FMT_SMF.1, FCS_COP.1/GP Secret Data Protection, FCS_RND.1, FMT_MTD.1/Unblock_PIN, FMT_MTD.1/UnblockChange_RAD	Section 8.3.1
OT.DTBS_Integrity_TOE	FDP_SDI.2/DTBS	Section 8.3.1
OT.EMSEC_Design	FPT_EMS.1, FPT_EMS.1/PIN-PUK-KEYS	Section 8.3.1
OT.Tamper_ID	FPT_PHP.1	Section 8.3.1
OT.Tamper_Resistance	FPT_PHP.3	Section 8.3.1
OT.TOE_SSCD_Auth	FIA_UAU.1, FIA_API.1	Section 8.3.1
OT.TOE_TC_SVD_Exp	FDP_ACF.1/SVD_Transfer, FDP_ACC.1/SVD_Transfer, FDP_DAU.2/SVD, FTP_ITC.1/SVD	Section 8.3.1
OT.Authentication_Secure	FCS_CKM.1/Session Keys, FCS_CKM.4, FCS_COP.1/GP Secret Data Protection, FCS_COP.1/SM in Confidentiality, FCS_COP.1/SM in Integrity, FCS_RND.1, FDP_RIP.1, FDP_SDI.2/Persistent, FIA_AFL.1/RAD, FIA_UID.1, FIA_UAU.1, FMT_SMR.1, FMT_SMF.1, FPT_EMS.1, FPT_FLS.1, FPT_PHP.3, FPT_TST.1, FCS_CKM.1/DH_PACE, FCS_COP.1/SIG_VER, FIA_UAU.1/PACE, FIA_UAU.5/PACE, FIA_AFL.1/AUTH, FIA_UAU.6/EAC, FIA_UID.1/PACE, FIA_UAU.4/PACE, FIA_UAU.6/PACE, FDP_ACC.1/TRM, FDP_ACF.1/TRM, FDP_UCT.1/TRM, FDP_UIT.1/TRM, FTP_ITC.1/PACE, FMT_SMR.1/PACE, FMT_MTD.1/CVCA_INI, FMT_MTD.1/CVCA_UPD, FMT_MTD.1/DATE, FMT_MTD.1/CAPK, FMT_MTD.1/KEY_READ, FMT_MTD.1/Initialize_PIN, FMT_MTD.1/Resume_PIN, FMT_MTD.1/Change_PIN, FMT_MTD.1/Unblock_PIN, FMT_MTD.1/UnblockChange_RAD, FMT_MTD.1/Erase_PIN, FMT_MTD.1/Reinitialize_PIN, FMT_MTD.1/UnblockChange_PUK, FMT_MTD.3,	Section 8.3.1

	FPT_EMS.1/PIN-PUK-KEYS, FMT_LIM.1, FMT_LIM.2, FIA_API.1/TOE Authentication, FIA_API.1	
OT.Key_Lifecycle_Security	FCS_CKM.1/SCD/SVD_Generation, FCS_CKM.4, FCS_COP.1/Digital Auth, FCS_COP.1/Enc Key Decipherment, FMT_MSA.2, FMT_MSA.3, FMT_SMR.1, FMT_SMF.1, FPT_TST.1	Section 8.3.1
OT.Keys_Secrecy	FCS_CKM.1/SCD/SVD_Generation, FCS_CKM.4, FDP_RIP.1, FDP_SDI.2/Persistent, FPT_FLS.1, FPT_PHP.3, FPT_TST.1, FPT_EMS.1/PIN-PUK-KEYS	Section 8.3.1
OT.TOE_AuthKey_Unique	FCS_CKM.1/SCD/SVD_Generation	Section 8.3.1
OT.Lifecycle_Management	FCS_COP.1/GP Secret Data Protection, FCS_RND.1, FDP_ACC.1/SCD/SVD_Generation, FDP_ACF.1/SCD/SVD_Generation, FDP_ACC.1/SVD_Transfer, FDP_ACF.1/SVD_Transfer, FDP_ACC.1/SCD_Import, FDP_ACF.1/SCD_Import, FDP_ACC.1/Signature_Creation, FDP_ACF.1/Signature_Creation, FIA_UID.1, FIA_UAU.1, FMT_MOF.1, FMT_MSA.1/Admin, FMT_MSA.2, FMT_MSA.3, FMT_MTD.1/Signatory, FMT_MTD.1/Admin, FMT_MTD.1/TOE State, FMT_SMR.1, FMT_SMF.1, FMT_MTD.1/Unblock_PIN, FMT_MTD.1/UnblockChange_RAD, FMT_MTD.1/Erase_PIN	Section 8.3.1
OT.eServices	FCS_COP.1/Digital Auth, FCS_COP.1/Enc Key Decipherment, FIA_AFL.1/RAD, FIA_UID.1, FIA_UAU.1, FMT_SMR.1, FMT_SMF.1	Section 8.3.1
OT.AC_Pers_EAC	FDP_RIP.1, FMT_SMF.1, FIA_UAU.1/PACE, FIA_AFL.1/AUTH, FIA_UID.1/PACE, FDP_ACC.1/TRM, FDP_ACF.1/TRM, FMT_SMR.1/PACE, FMT_MTD.1/KEY_READ, FMT_MTD.1/Initialize_PIN, FMT_MTD.1/Resume_PIN, FMT_MTD.1/Change_PIN, FMT_MTD.1/Unblock_PIN, FMT_MTD.1/UnblockChange_RAD, FMT_MTD.1/Erase_PIN, FMT_MTD.1/Reinitialize_PIN, FMT_MTD.1/UnblockChange_PUK	Section 8.3.1
OT.Tracing	FIA_AFL.1/AUTH, FTP_ITC.1/PACE	Section 8.3.1

Table 12 Security Objectives and SFRs - Coverage

Security Functional Requirements	Security Objectives
FCS_CKM.1/SCD/SVD_Generation	OT.Lifecycle_Security, OT.SCD_Unique, OT.SCD_SVD_Corresp, OT.SCD_Secrecy, OT.Key_Lifecycle_Security, OT.Keys_Secrecy, OT.TOE_AuthKey_Unique
FCS_CKM.4	OT.Lifecycle_Security, OT.SCD_Secrecy, OT.Authentication_Secure, OT.Key_Lifecycle_Security, OT.Keys_Secrecy

FDP_ACC.1/SCD/SVD_Generation	OT.Lifecycle_Security, OT.SCD/SVD_Auth_Gen, OT.Lifecycle_Management
FDP_ACF.1/SCD/SVD_Generation	OT.Lifecycle_Security, OT.SCD/SVD_Auth_Gen, OT.Lifecycle_Management
FDP_ACC.1/SVD_Transfer	OT.Lifecycle_Security, OT.TOE_TC_SVD_Exp, OT.Lifecycle_Management
FDP_ACF.1/SVD_Transfer	OT.Lifecycle_Security, OT.TOE_TC_SVD_Exp, OT.Lifecycle_Management
FDP_ACC.1/SCD_Import	OT.Lifecycle_Security, OT.SCD_Auth_Imp, OT.Lifecycle_Management
FDP_ACF.1/SCD_Import	OT.Lifecycle_Security, OT.SCD_Auth_Imp, OT.Lifecycle_Management
FDP_RIP.1	OT.SCD_Secrecy, OT.Sigy_SigF, OT.Authentication_Secure, OT.Keys_Secrecy, OT.AC_Pers_EAC
FDP_SDI.2/Persistent	OT.SCD_SVD_Corresp, OT.SCD_Secrecy, OT.Sig_Secure, OT.Authentication_Secure, OT.Keys_Secrecy
FDP_ITC.1/SCD	OT.Lifecycle_Security
FDP_UCT.1/SCD	OT.Lifecycle_Security, OT.SCD_Secrecy
FDP_DAU.2/SVD	OT.TOE_TC_SVD_Exp
FIA_UID.1	OT.SCD/SVD_Auth_Gen, OT.SCD_Auth_Imp, OT.Sigy_SigF, OT.Authentication_Secure, OT.Lifecycle_Management, OT.eServices
FIA_UAU.1	OT.SCD/SVD_Auth_Gen, OT.SCD_Auth_Imp, OT.Sigy_SigF, OT.TOE_SSCD_Auth, OT.Authentication_Secure, OT.Lifecycle_Management, OT.eServices
FIA_API.1	OT.TOE_SSCD_Auth, OT.Authentication_Secure
FMT_SMR.1	OT.Lifecycle_Security, OT.Sigy_SigF, OT.Authentication_Secure, OT.Key_Lifecycle_Security, OT.Lifecycle_Management, OT.eServices
FMT_SMF.1	OT.Lifecycle_Security, OT.SCD_SVD_Corresp, OT.Sigy_SigF, OT.Authentication_Secure, OT.Key_Lifecycle_Security, OT.Lifecycle_Management, OT.eServices, OT.AC_Pers_EAC
FMT_MSA.1/Admin	OT.Lifecycle_Security, OT.SCD/SVD_Auth_Gen, OT.Lifecycle_Management
FMT_MSA.2	OT.Lifecycle_Security, OT.SCD/SVD_Auth_Gen, OT.Sigy_SigF, OT.Key_Lifecycle_Security, OT.Lifecycle_Management
FMT_MSA.3	OT.Lifecycle_Security, OT.SCD/SVD_Auth_Gen, OT.Sigy_SigF, OT.Key_Lifecycle_Security, OT.Lifecycle_Management
FMT_MSA.4	OT.Lifecycle_Security, OT.SCD/SVD_Auth_Gen, OT.SCD_SVD_Corresp, OT.Sigy_SigF

FMT_MTD.1/Admin	OT.Lifecycle_Security, OT.Sigy_SigF, OT.Lifecycle_Management
FPT_EMS.1	OT.SCD_Secrecy, OT.EMSEC_Design, OT.Authentication_Secure
FPT_FLS.1	OT.SCD_Secrecy, OT.Authentication_Secure, OT.Keys_Secrecy
FPT_PHP.1	OT.Tamper_ID
FPT_PHP.3	OT.SCD_Secrecy, OT.Tamper_Resistance, OT.Authentication_Secure, OT.Keys_Secrecy
FPT_TST.1	OT.Lifecycle_Security, OT.SCD_Secrecy, OT.Sig_Secure, OT.Authentication_Secure, OT.Key_Lifecycle_Security, OT.Keys_Secrecy
FTP_ITC.1/SCD	OT.Lifecycle_Security, OT.SCD_Secrecy
FTP_ITC.1/SVD	OT.TOE_TC_SVD_Exp
FCS_COP.1/Sign	OT.Lifecycle_Security, OT.Sig_Secure
FDP_ACC.1/Signature_Creation	OT.Lifecycle_Security, OT.Sigy_SigF, OT.Lifecycle_Management
FDP_ACF.1/Signature_Creation	OT.Lifecycle_Security, OT.Sigy_SigF, OT.Lifecycle_Management
FDP_SDI.2/DTBS	OT.Sigy_SigF, OT.DTBS_Integrity_TOE
FIA_AFL.1/RAD	OT.Sigy_SigF, OT.Authentication_Secure, OT.eServices
FMT_MOF.1	OT.Lifecycle_Security, OT.Sigy_SigF, OT.Lifecycle_Management
FMT_MSA.1/Signatory	OT.Lifecycle_Security, OT.Sigy_SigF
FMT_MTD.1/Signatory	OT.Lifecycle_Security, OT.Sigy_SigF, OT.Lifecycle_Management
FCS_CKM.1/Session Keys	OT.Authentication_Secure
FCS_CKM.1/DH_PACE	OT.Authentication_Secure
FCS_COP.1/GP Secret Data Protection	OT.Sigy_SigF, OT.Authentication_Secure, OT.Lifecycle_Management
FCS_COP.1/SM in Confidentiality	OT.Authentication_Secure
FCS_COP.1/SM in Integrity	OT.Authentication_Secure
FCS_COP.1/Digital Auth	OT.Key_Lifecycle_Security, OT.eServices
FCS_COP.1/Enc Key Decipherment	OT.Key_Lifecycle_Security, OT.eServices
FCS_COP.1/SIG_VER	OT.Authentication_Secure
FCS_RND.1	OT.Sigy_SigF, OT.Authentication_Secure, OT.Lifecycle_Management
FIA_UID.1/PACE	OT.Authentication_Secure, OT.AC_Pers_EAC
FIA_UAU.1/PACE	OT.Authentication_Secure, OT.AC_Pers_EAC
FIA_UAU.4/PACE	OT.Authentication_Secure
FIA_UAU.5/PACE	OT.Authentication_Secure
FIA_UAU.6/PACE	OT.Authentication_Secure
FIA_UAU.6/EAC	OT.Authentication_Secure

FIA_AFL.1/AUTH	OT.Authentication_Secure, OT.AC_Pers_EAC, OT.Tracing
FIA_API.1/TOE Authentication	OT.Authentication_Secure
FDP_ACC.1/TRM	OT.Authentication_Secure, OT.AC_Pers_EAC
FDP_ACF.1/TRM	OT.Authentication_Secure, OT.AC_Pers_EAC
FDP_UCT.1/TRM	OT.Authentication_Secure
FDP_UIT.1/TRM	OT.Authentication_Secure
FTP_ITC.1/PACE	OT.Authentication_Secure, OT.Tracing
FMT_SMR.1/PACE	OT.Authentication_Secure, OT.AC_Pers_EAC
FMT_MTD.1/CVCA_INI	OT.Authentication_Secure
FMT_MTD.1/CVCA_UPD	OT.Authentication_Secure
FMT_MTD.1/DATE	OT.Authentication_Secure
FMT_MTD.1/CAPK	OT.Authentication_Secure
FMT_MTD.1/KEY_READ	OT.Authentication_Secure, OT.AC_Pers_EAC
FMT_MTD.1/Initialize_PIN	OT.Authentication_Secure, OT.AC_Pers_EAC
FMT_MTD.1/Resume_PIN	OT.Authentication_Secure, OT.AC_Pers_EAC
FMT_MTD.1/Change_PIN	OT.Authentication_Secure, OT.AC_Pers_EAC
FMT_MTD.1/Unblock_PIN	OT.Sigy_SigF, OT.Authentication_Secure, OT.Lifecycle_Management, OT.AC_Pers_EAC
FMT_MTD.1/UnblockChange_RAD	OT.Lifecycle_Security, OT.Sigy_SigF, OT.Authentication_Secure, OT.Lifecycle_Management, OT.AC_Pers_EAC
FMT_MTD.1/Erase_PIN	OT.Lifecycle_Security, OT.Authentication_Secure, OT.Lifecycle_Management, OT.AC_Pers_EAC
FMT_MTD.1/Reinitialize_PIN	OT.Authentication_Secure, OT.AC_Pers_EAC
FMT_MTD.1/UnblockChange_PUK	OT.Authentication_Secure, OT.AC_Pers_EAC
FMT_MTD.1/TOE State	OT.Lifecycle_Management
FMT_MTD.3	OT.Authentication_Secure
FMT_LIM.1	OT.Authentication_Secure
FMT_LIM.2	OT.Authentication_Secure
FPT_EMS.1/PIN-PUK-KEYS	OT.EMSEC_Design, OT.Authentication_Secure, OT.Keys_Secrecy

Table 13 SFRs and Security Objectives

8.3.3 Dependencies

8.3.3.1 SFRs Dependencies

Requirements	CC Dependencies	Satisfied Dependencies
FCS_CKM.1/Session Keys	(FCS_CKM.2 or FCS_COP.1) and (FCS_CKM.4)	FCS_COP.1/SM in Confidentiality, FCS_COP.1/SM in Integrity, FCS_CKM.4

ComblCAO Applet v2.1 in SSCD configuration on Cosmo V9.2 Public Security Target

FCS_CKM.1/DH_PACE	(FCS_CKM.2 or FCS_COP.1) and (FCS_CKM.4)	FCS_COP.1/SM in Confidentiality, FCS_COP.1/SM in Integrity, FCS_CKM.4
FCS_COP.1/GP Secret Data Protection	(FCS_CKM.1 or FDP_ITC.1 or FDP_ITC.2) and (FCS_CKM.4)	FCS_CKM.1/Session Keys, FCS_CKM.4
FCS_COP.1/SM in Confidentiality	(FCS_CKM.1 or FDP_ITC.1 or FDP_ITC.2) and (FCS_CKM.4)	FCS_CKM.1/Session Keys, FCS_CKM.4
FCS_COP.1/SM in Integrity	(FCS_CKM.1 or FDP_ITC.1 or FDP_ITC.2) and (FCS_CKM.4)	FCS_CKM.1/Session Keys, FCS_CKM.4
FCS_COP.1/Digital Auth	(FCS_CKM.1 or FDP_ITC.1 or FDP_ITC.2) and (FCS_CKM.4)	FCS_CKM.1/SCD/SVD_Generation, FCS_CKM.4
FCS_COP.1/Enc Key Decipherment	(FCS_CKM.1 or FDP_ITC.1 or FDP_ITC.2) and (FCS_CKM.4)	FCS_CKM.1/SCD/SVD_Generation, FCS_CKM.4
FCS_COP.1/SIG_VER	(FCS_CKM.1 or FDP_ITC.1 or FDP_ITC.2) and (FCS_CKM.4)	FCS_CKM.1/DH_PACE, FCS_CKM.4
FCS_RND.1	No Dependencies	
FIA_UID.1/PACE	No Dependencies	
FIA_UAU.1/PACE	(FIA_UID.1)	FIA_UID.1/PACE
FIA_UAU.4/PACE	No Dependencies	
FIA_UAU.5/PACE	No Dependencies	
FIA_UAU.6/PACE	No Dependencies	
FIA_UAU.6/EAC	No Dependencies	
FIA_AFL.1/AUTH	(FIA_UAU.1)	FIA_UAU.1/PACE
FIA_API.1/TOE Authentication	No Dependencies	
FDP_ACC.1/TRM	(FDP_ACF.1)	FDP_ACF.1/TRM
FDP_ACF.1/TRM	(FDP_ACC.1) and (FMT_MSA.3)	FDP_ACC.1/TRM, FMT_MSA.3

FDP_UCT.1/TRM	(FDP_ACC.1 or FDP_IFC.1) and (FTP_ITC.1 or FTP_TRP.1)	FDP_ACC.1/TRM, FTP_ITC.1/PACE
FDP_UIT.1/TRM	(FDP_ACC.1 or FDP_IFC.1) and (FTP_ITC.1 or FTP_TRP.1)	FDP_ACC.1/TRM, FTP_ITC.1/PACE
FTP_ITC.1/PACE	No Dependencies	
FMT_SMR.1/PACE	(FIA_UID.1)	FIA_UID.1/PACE
FMT_MTD.1/CVCA_INI	(FMT_SMF.1) and (FMT_SMR.1)	FMT_SMR.1/PACE, FMT_SMF.1
FMT_MTD.1/CVCA_UPD	(FMT_SMF.1) and (FMT_SMR.1)	FMT_SMR.1/PACE, FMT_SMF.1
FMT_MTD.1/DATE	(FMT_SMF.1) and (FMT_SMR.1)	FMT_SMR.1/PACE, FMT_SMF.1
FMT_MTD.1/CAPK	(FMT_SMF.1) and (FMT_SMR.1)	FMT_SMR.1/PACE, FMT_SMF.1
FMT_MTD.1/KEY_READ	(FMT_SMF.1) and (FMT_SMR.1)	FMT_SMR.1/PACE, FMT_SMF.1
FMT_MTD.1/Initialize_PIN	(FMT_SMF.1) and (FMT_SMR.1)	FMT_SMR.1/PACE, FMT_SMF.1
FMT_MTD.1/Resume_PIN	(FMT_SMF.1) and (FMT_SMR.1)	FMT_SMR.1/PACE, FMT_SMF.1
FMT_MTD.1/Change_PIN	(FMT_SMF.1) and (FMT_SMR.1)	FMT_SMR.1/PACE, FMT_SMF.1
FMT_MTD.1/Unblock_PIN	(FMT_SMF.1) and (FMT_SMR.1)	FMT_SMR.1/PACE, FMT_SMF.1
FMT_MTD.1/UnblockChange_RAD	(FMT_SMF.1) and (FMT_SMR.1)	FMT_SMR.1/PACE, FMT_SMF.1
FMT_MTD.1/Erase_PIN	(FMT_SMF.1) and (FMT_SMR.1)	FMT_SMR.1/PACE, FMT_SMF.1
FMT_MTD.1/Reinitialize_PIN	(FMT_SMF.1) and (FMT_SMR.1)	FMT_SMR.1/PACE, FMT_SMF.1

FMT_MTD.1/UnblockChange_PUK	(FMT_SMF.1) and (FMT_SMR.1)	FMT_SMR.1/PACE, FMT_SMF.1
FMT_MTD.1/TOE State	(FMT_SMF.1) and (FMT_SMR.1)	FMT_SMR.1, FMT_SMF.1
FMT_MTD.3	(FMT_MTD.1)	FMT_MTD.1/CVCA_INI, FMT_MTD.1/CVCA_UPD, FMT_MTD.1/DATE
FMT_LIM.1	(FMT_LIM.2)	FMT_LIM.2
FMT_LIM.2	(FMT_LIM.1)	FMT_LIM.1
FPT_EMS.1/PIN-PUK-KEYS	No Dependencies	
FCS_CKM.1/SCD/SVD_Generation	(FCS_CKM.2 or FCS_COP.1) and (FCS_CKM.4)	FCS_CKM.4, FCS_COP.1/Sign
FCS_CKM.4	(FCS_CKM.1 or FDP_ITC.1 or FDP_ITC.2)	FCS_CKM.1/SCD/SVD_Generation, FDP_ITC.1/SCD
FDP_ACC.1/SCD/SVD_Generation	(FDP_ACF.1)	FDP_ACF.1/SCD/SVD_Generation
FDP_ACF.1/SCD/SVD_Generation	(FDP_ACC.1) and (FMT_MSA.3)	FDP_ACC.1/SCD/SVD_Generation, FMT_MSA.3
FDP_ACC.1/SVD_Transfer	(FDP_ACF.1)	FDP_ACF.1/SVD_Transfer
FDP_ACF.1/SVD_Transfer	(FDP_ACC.1) and (FMT_MSA.3)	FDP_ACC.1/SVD_Transfer, FMT_MSA.3
FDP_ACC.1/SCD_Import	(FDP_ACF.1)	FDP_ACF.1/SCD_Import
FDP_ACF.1/SCD_Import	(FDP_ACC.1) and (FMT_MSA.3)	FDP_ACC.1/SCD_Import, FMT_MSA.3
FDP_RIP.1	No Dependencies	
FDP_SDI.2/Persistent	No Dependencies	
FDP_ITC.1/SCD	(FDP_ACC.1 or FDP_IFC.1) and (FMT_MSA.3)	FDP_ACC.1/SCD_Import, FMT_MSA.3
FDP_UCT.1/SCD	(FDP_ACC.1 or FDP_IFC.1) and (FTP_ITC.1 or FTP_TRP.1)	FDP_ACC.1/SCD_Import, FTP_ITC.1/SCD
FDP_DAU.2/SVD	(FIA_UID.1)	FIA_UID.1
FIA_UID.1	No Dependencies	
FIA_UAU.1	(FIA_UID.1)	FIA_UID.1

FIA_API.1	No Dependencies	
FMT_SMR.1	(FIA_UID.1)	FIA_UID.1
FMT_SMF.1	No Dependencies	
FMT_MSA.1/Admin	(FDP_ACC.1 or FDP_IFC.1) and (FMT_SMF.1) and (FMT_SMR.1)	FDP_ACC.1/SCD/SVD_Generation, FDP_ACC.1/SVD_Transfer, FDP_ACC.1/SCD_Import, FMT_SMR.1, FMT_SMF.1, FDP_ACC.1/Signature_Creation
FMT_MSA.2	(FDP_ACC.1 or FDP_IFC.1) and (FMT_MSA.1) and (FMT_SMR.1)	FDP_ACC.1/SCD/SVD_Generation, FMT_SMR.1, FMT_MSA.1/Admin, FDP_ACC.1/Signature_Creation, FMT_MSA.1/Signatory
FMT_MSA.3	(FMT_MSA.1) and (FMT_SMR.1)	FMT_SMR.1, FMT_MSA.1/Admin, FMT_MSA.1/Signatory
FMT_MSA.4	(FDP_ACC.1 or FDP_IFC.1)	FDP_ACC.1/SCD/SVD_Generation, FDP_ACC.1/Signature_Creation
FMT_MTD.1/Admin	(FMT_SMF.1) and (FMT_SMR.1)	FMT_SMR.1, FMT_SMF.1
FPT_EMS.1	No Dependencies	
FPT_FLS.1	No Dependencies	
FPT_PHP.1	No Dependencies	
FPT_PHP.3	No Dependencies	
FPT_TST.1	No Dependencies	
FTP_ITC.1/SCD	No Dependencies	
FTP_ITC.1/SVD	No Dependencies	
FCS_COP.1/Sign	(FCS_CKM.1 or FDP_ITC.1 or FDP_ITC.2) and (FCS_CKM.4)	FCS_CKM.1/SCD/SVD_Generation, FCS_CKM.4, FDP_ITC.1/SCD
FDP_ACC.1/Signature_Creation	(FDP_ACF.1)	FDP_ACF.1/Signature_Creation
FDP_ACF.1/Signature_Creation	(FDP_ACC.1) and (FMT_MSA.3)	FMT_MSA.3, FDP_ACC.1/Signature_Creation
FDP_SDI.2/DTBS	No Dependencies	
FIA_AFL.1/RAD	(FIA_UAU.1)	FIA_UAU.1

FMT_MOF.1	(FMT_SMF.1) and (FMT_SMR.1)	FMT_SMR.1, FMT_SMF.1
FMT_MSA.1/Signatory	(FDP_ACC.1 or FDP_IFC.1) and (FMT_SMF.1) and (FMT_SMR.1)	FMT_SMR.1, FMT_SMF.1, FDP_ACC.1/Signature_Creation
FMT_MTD.1/Signatory	(FMT_SMF.1) and (FMT_SMR.1)	FMT_SMR.1, FMT_SMF.1

Table 14 SFRs Dependencies

8.3.3.2 SARs Dependencies

Requirements	CC Dependencies	Satisfied Dependencies
ADV_ARC.1	(ADV_FSP.1) and (ADV_TDS.1)	ADV_FSP.5, ADV_TDS.4
ADV_FSP.5	(ADV_IMP.1) and (ADV_TDS.1)	ADV_IMP.1, ADV_TDS.4
ADV_IMP.1	(ADV_TDS.3) and (ALC_TAT.1)	ADV_TDS.4, ALC_TAT.2
ADV_TDS.4	(ADV_FSP.5)	ADV_FSP.5
ADV_INT.2	(ADV_IMP.1) and (ADV_TDS.3) and (ALC_TAT.1)	ADV_IMP.1, ADV_TDS.4, ALC_TAT.2
AGD_OPE.1	(ADV_FSP.1)	ADV_FSP.5
AGD_PRE.1	No Dependencies	
ALC_CMC.4	(ALC_CMS.1) and (ALC_DVS.1) and (ALC_LCD.1)	ALC_CMS.5, ALC_DVS.2, ALC_LCD.1
ALC_CMS.5	No Dependencies	
ALC_DEL.1	No Dependencies	
ALC_DVS.2	No Dependencies	
ALC_LCD.1	No Dependencies	
ALC_TAT.2	(ADV_IMP.1)	ADV_IMP.1
ASE_CCL.1	(ASE_ECD.1) and (ASE_INT.1) and (ASE_REQ.1)	ASE_ECD.1, ASE_INT.1, ASE_REQ.2
ASE_ECD.1	No Dependencies	
ASE_INT.1	No Dependencies	
ASE_OBJ.2	(ASE_SPD.1)	ASE_SPD.1
ASE_REQ.2	(ASE_ECD.1) and (ASE_OBJ.2)	ASE_ECD.1, ASE_OBJ.2
ASE_SPD.1	No Dependencies	
ASE_TSS.1	(ADV_FSP.1) and (ASE_INT.1) and (ASE_REQ.1)	ADV_FSP.5, ASE_INT.1, ASE_REQ.2
ATE_COV.2	(ADV_FSP.2) and (ATE_FUN.1)	ADV_FSP.5, ATE_FUN.1
ATE_DPT.3	(ADV_ARC.1) and (ADV_TDS.4) and (ATE_FUN.1)	ADV_ARC.1, ADV_TDS.4, ATE_FUN.1
ATE_FUN.1	(ATE_COV.1)	ATE_COV.2

ATE_IND.2	(ADV_FSP.2) and (AGD_OPE.1) and (AGD_PRE.1) and (ATE_COV.1) and (ATE_FUN.1)	ADV_FSP.5, AGD_OPE.1, AGD_PRE.1, ATE_COV.2, ATE_FUN.1
AVA_VAN.5	(ADV_ARC.1) and (ADV_FSP.4) and (ADV_IMP.1) and (ADV_TDS.3) and (AGD_OPE.1) and (AGD_PRE.1) and (ATE_DPT.1)	ADV_ARC.1, ADV_FSP.5, ADV_IMP.1, ADV_TDS.4, AGD_OPE.1, AGD_PRE.1, ATE_DPT.3

Table 15 SARs Dependencies

8.3.4 Rationale for the Security Assurance Requirements

8.3.5 AVA_VAN.5 Advanced methodical vulnerability analysis

The TOE is intended to function in a variety of signature creation systems for sualified electronic signatures. Due to the nature of its intended applications, i.e. the TOE may be issued to users and may not be directly under the control of trained and dedicated administrators. Insecure states shall be easy to detect and the TOE shall be shown to be highly resistant to penetration attacks to meet the security objectives OT.SCD_Secrecy, OT.Sigy_SigF, OT.Sig_Secure and OT.Keys_Secrecy. This assurance requirement is achieved by the AVA_VAN.5 component. Independent vulnerability analysis is based on highly detailed technical information. The attacker is assumed to be thoroughly familiar with the specific implementation of the TOE. The attacker is presumed to have a high level of technical sophistication.

8.3.6 ALC_DVS.2 Sufficiency of security measures

In order to protect the TOE on development Phase, the component ALC_DVS.2 was added. This latter requires security documentation justifying that the security measures provide the necessary level of protection to maintain the confidentiality and integrity of the TOE.

9 TOE Summary Specification

9.1 TOE Summary Specification

This section provides a summary of the security functions implemented by the TOE in order to fulfil the security functional requirements. The summary is structured in security functions.

The security functionalities concerning the IC and the JC Platform are described in [ST-IC], [ST-PL] and are not redefined in this security target, although they must be considered for the TOE.

9.1.1 Description

The TOE inherits all the security functions provided by the underlying javacard open platform [PLT] (see the Security target). On top of these, it adds some supplemental security functions that are described hereafter.

SF.PIN_MGT

This security function is involved in the management of the PINs (PIN, PUK and RAD). PINs are secret data used so that a natural person can authenticate itself to the TOE. This security function (1) provides all management operations on these PINs (verification, change, unblocking, unblocking and change, initialization, re initialization) and (2) enforces the access control policies over these operations.

The natural person can authenticate itself to the TOE via the PACE protocol and/or the VERIFY PIN command. Notice that The usage of PACE protocol is mandatory only for contactless mode. The verification process uses a velocity checking mechanism, thus a remaining tries counter and a maximum error counter are defined for each PIN. If the verification fails, the tries counter is decremented by one and an error status that contains the remaining attempts is returned by the application. When all available tries have failed, the PIN is suspended or blocked and can no longer be used. Note that a successful verification of the PIN resets its remaining tries counter to the maximum error counter.

SF.SIG

This security function manages the signature creation service.

It enforces access control over the signature creation service:

In phase 6, it ensures the signature computation function is not accessible, and in particular that the personalization agent cannot sign on behalf of the Signatory.

In phase 7, it ensures the signature creation feature is activated only by the signatory.

In phase 7, it enforces the integrity of DTBS, and ensures that R.Sigy is successfully authenticated before creating the signature.

The security function ensures the data hashing (if hash on card, or partial hashing is used), and the secure signature computation using the private key (SCD), either with RSA or EC-DSA cryptography.

This security function relies on SF.PIN_MGT to authenticate the Signatory.

SF.AUTH

This security function manages the authentication protocols supported by the TOE.

This security function supports the authentication with the personalization agent in phase 6. This authentication relies on a mutual authentication protocol authenticating (1) the TOE to the personalization agent, and (2) the personalization agent to the TOE. It relies on symmetric master key sets shared by the TOE and the personalization agent that may be DES or AES symmetric keys (depending on the type of Secure Channel Protocol – SCP). Upon successful completion of the authentication, both parties (TOE and personalization agent) generate session keys that may be used to establish a secure channel thanks to SF.SM. This secure channel allows protecting the communication between them in integrity, authenticity and confidentiality. Each symmetric master key sets is associated to an error counter, which aims at ensuring its protecting against brute force attacks. Upon each wrong authentication attempt, the authentication processing time is slowed down (increasingly). Once a successful authentication takes place, the slow down mechanisms is cancelled.

In phase 7, this security function also supports the Extended Access Control protocol (EAC) made up with Chip authentication (CA) and Terminal Authentication (TA). This protocol allows

(1) a mutual authentication between the TOE and a remote terminal, and (2) the generation of session keys used to establish a secure channel thanks to SF.SM. This secure channel protects the communication between them in integrity, authenticity and confidentiality. This authentication is based on PKI scheme: each party (TOE and remote terminal) uses (1) an authentication private key and (2) digital certificates containing the corresponding authentication public key and linking it to the root of trust known by the other party, to authenticate itself to the other party. This security function manages the verification and processing of the certificates received from the remote terminal (that have a specific format named Card Verifiable Certificate – CVC). In particular, this security function computes the effective authorization of the remote terminal. The Extended Access Control (EAC) protocol is used to establish a trusted channel with the CGA prior to SCD/SVD generation.

In phase 7, this security function also supports the PACE protocol. This protocol is a human to machine authentication protocol allowing to (1) authenticate a natural person to the TOE by using a PIN or (2) prove the holder has the TOE in hand (using CAN) and (3) creating a secure channel between the TOE and a device used to initiate the communication. This protocol is designed to protect the secrecy of the PIN in the course of the authentication so that it can't be intercepted during the communication, or deduced through crypto analysis. Upon successful completion of PACE authentication, session keys used to establish a secure channel thanks to SF.SM are generated. This secure function also manage error counter on the credentials used to perform the authentication. Upon failure, the error counter of the credentials used to initiate the PACE authentication is decreased until it is blocked.

Once blocked, a secret credential (PINs) can't be used anymore to perform a PACE protocol, while for CAN, the PACE protocol is slowed down.

Upon successful PACE authentication, the error counter of the credentials used to initiate the PACE authentication is reset to its maximum value; Last but not least, this security function also handles the suspension mechanisms protecting the PINs against Denial Of services attacks (not applicable to CAN). When the remaining number of tries is set to '1', any attempt to perform a PACE authentication in contactless mode using a PIN credential will require it to be made through a secure channel generated using PACE authentication performed using the CAN.

In phase 7, this security function also provides mechanisms to authenticate the SSCD and prove its identity (thanks to the Chip Authentication mechanism described above).

SF.SM

This security function ensures the protection of communication between the TOE and an external entity. As such, this security function maintains a trusted channel between the TOE and an external entity.

This security function requires the TOE and the external entity to establish first a trusted channel using an authentication supported by SF.AUTH.

This security function ensures the following properties:

In phase 6, it ensures the confidentiality, integrity and authenticity of the private keys (including the SCD), and the PINs (including the RAD);

In phase 6, it ensures the integrity and authenticity of the asymmetric public key (including the SVD) when being exported to the outside

In phase 7, it ensures the confidentiality, integrity and authenticity of communication between the TOE and the external entity with which an authentication was performed;

In phase 6, the confidentiality, integrity and authenticity of communication is ensured by symmetric cryptography. Sensitive data (such as SCD or PINs) are encrypted using a dedicated symmetric session keys for data encryption generated from the seed agreed during the authentication with the personalization agent (see SF.AUTH). On top of that, data are encrypted and signed using symmetric session keys generated from the seed agreed during the authentication with the personalization agent (see SF.AUTH).

In phase 7, the confidentiality, integrity and authenticity of communication is ensured by symmetric cryptography. Data are encrypted and signed using symmetric session keys generated from the seed agreed during the Extended Access Control (EAC) or PACE protocol (see SF.AUTH). Moreover, the protection against replay attacks is ensured by the Message Authentication Code (MAC) which is computed using a dynamic ICV, incremented at each new command.

This security function is also in charge of:

generating the session keys from the seed computed by SF.AUTH. These session keys are ephemeral and unique, as the seed is computed from random numbers generated by the TOE and the external entity.

destroying the session keys in case an error is detected (data not authentic or not integer), or when a command in plain text is sent.

providing CGA the ability to verify evidence of the validity of the SVD and the identity of the user that generated the evidence.

This security function supports SF.AUTH to prove the identity of the SSCD and the TOE holder.

SF.KEY_MGT

This security function is involved in the management of the asymmetric keys (including SCDs and SVDs).

It enforces access control over any management operation on the keys:

In phase 6, it only allows the key (including the SCD) to be loaded, generated and exported (for the public keys) by the personalization agent. It also requires the private keys to be encrypted in order to ensure their confidentiality. This security function ensures the personalization agent (1) can't use the keys it has loaded or generated. and (2) can't impersonate the associated role (in case of authentication keys), or create a signature with the SCD;

In phase 7, it allows managing all the keys (including the SCD) by providing generation and export of the corresponding public key. It also enforces access control policies on these operations.

This security function also ensures that after update or generation, the former key (including SCD and SVD) is securely destroyed.

SF.CONF

This security function manages the configuration of the TOE in phase 6. For instance it allows the modification of the TOE State in phase 6.

This security function ensures an access control over these operations. Only the successfully authenticated Personalization Agent can modify these attributes.

This security function relies on SF.AUTH to authenticate the personalization agent.

SF.ESERVICE

This security function enables to perform digital authentication and electronic services. It is active in phase 7.

This security function offers the following services:

Digital authentication;

Decryption key decipherment;

This security function relies on SF.KEY_MGT which provides management of the keys on which these services rely.

SF.SAFESTATE_MGT

This security function ensures the TOE is always in a safe state. It monitors the integrity of the TOE, its assets and the TSF data by performing self-tests. When an unexpected event occurs (loss of power, loss of integrity, tearing,...), it ensures

the TOE returns in a safe state

all sensitive data are erased

the TOE returns in a restrictive secure state

When a major issue is detected, the security function ensures the destruction of the TOE, so that the assets are not accessible anymore.

SF.PHYS

This security function protects the TOE against physical attacks, so that the integrity and confidentiality of the TOE is ensured, including keys, user data, CPLC data, configuration data and TOE life cycle. It detects physical tampering, responds automatically and also controls the emanations sent out by the TOE. It furthermore prevents deploying test features after TOE delivery.

9.2 SFRs and TSS

9.2.1 SFRs and TSS - Rationale

9.2.1.1 TOE Summary Specification

Description

SF.PIN_MGT The implementation of this security function contributes to:

FIA_UID.1, FIA_UAU.1, FIA_UID.1/PACE, FIA_UAU.1/PACE, FIA_UAU.4/PACE, FIA_UAU.5/PACE that provide user identification and user authentication prior to enabling access to authorized functions.

FIA_AFL.1/RAD, FIA_AFL.1/AUTH that handle the authentication failure.

FMT_SMR.1, FMT_SMR.1/PACE that define security roles for the TOE.

FMT_SMF.1.

FTP_ITC.1/PACE that ensures a trusted channel between them TOE and a PACE terminal to protect the exchanged data in contactless from modification and disclosure.

FMT_MTD.1/Admin, FMT_MTD.1/Signatory, FMT_MTD.1.1/Initialize_PIN,

FMT_MTD.1.1/Resume_PIN, FMT_MTD.1/Change_PIN, FMT_MTD.1/Unblock_PIN, FMT_MTD.1.1/Unblock

Change_RAD, FMT_MTD.1.1/Erase_PIN, FMT_MTD.1.1/Reinitialize_PIN,

FMT_MTD.1.1/UnblockChange_PUK, FMT_MTD.3 that manage the TSFs date by defining access rules.

SF.SIG The implementation of this security function contributes to:

FCS_COP.1/Sign that provide cryptographic operations.

FDP_ACC.1/Signature_Creation, FDP_ACF.1/Signature_Creation that enforce the signature creation SFP.

FIA_UID.1, FIA_UAU.1 that provide user identification and user authentication prior to enabling access to authorized functions.

FMT_MSA.1/Signatory, FMT_MSA.2, FMT_MSA.3, FMT_MSA.4 that manages the access right policy of the TOE.

FMT_MOF.1 that ensures the management of the signature creation function.

FMT_SMF.1.

FDP_SDI.2/DTBS that ensures the integrity of DTBS.

SF.AUTH The implementation of this security function contributes to:

FCS_CKM.1.1/DH_PACE that ensures cryptographic key generation.

FCS_COP.1/SM in confidentiality, FCS_COP.1/SM in integrity, FCS_COP.1/GP secret data protection,

FCS_RND.1, FCS_COP.1.1/SIG_VER that provide cryptographic operations.

FIA_API.1, FIA_API.1/TOE Authentication

FMT_SMR.1, FMT_SMR.1/PACE that define security roles for the TOE.

FMT_SMF.1

FMT_MSA.1/Admin, FMT_MSA.2, FMT_MSA.3, FMT_MSA.4 that manages the access right policy of the TOE.

FTP_ITC.1/SCD, FTP_ITC.1/SVD, FTP_ITC.1/PACE that ensure a trusted channel between them TOE and a Terminal to protect the exchanged data from modification and disclosure.

FIA_UID.1, FIA_UAU.1, FIA_UID.1/PACE, FIA_UAU.1/PACE, FIA_UAU.4/PACE, FIA_UAU.5/PACE,

FIA_UAU.6/PACE, FIA_UAU.6/EAC that provide user identification and user authentication prior to enabling access to authorized functions.

FIA_AFL.1/AUTH that handles the authentication failure.

FDP_ACC.1/TRM, FDP_ACF.1/TRM that ensure that only an authorized user under specific conditions can perform a dedicated operation, and in particular, that only users authenticated as authenticated terminal.

FDP_UCT.1/TRM that ensures data exchange confidentiality.

FMT_MTD.1.1/CVCA_INI, FMT_MTD.1.1/CVCA_UPD, FMT_MTD.1.1/DATE, FMT_MTD.1.1/CAPK,

FMT_MTD.1.1/KEY_READ, FMT_MTD.3 that manage the TSFs date by defining access rules.

SF.SM The implementation of this security function contributes to:

FCS_CKM.1/Session Keys that ensure cryptographic key generation.

FCS_COP.1/SM in confidentiality, FCS_COP.1/SM in integrity, FCS_COP.1/GP secret data protection, FCS_COP.1.1/SIG_VER that provide cryptographic operations.

FDP_DAU.2/SVD that ensures that exported SVD to the CGA is authenticated and unmodified.

FIA_API.1, FIA_API.1/TOE Authentication.

FTP_ITC.1/SCD, FTP_ITC.1/SVD, FTP_ITC.1/PACE that ensure a trusted channel between them TOE and a Terminal to protect the exchanged data from modification and disclosure.

FIA_UID.1/PACE, FIA_UAU.1/PACE, FIA_UAU.4/PACE, FIA_UAU.5/PACE, FIA_UAU.6/PACE,

FIA_UAU.6/EAC that provide user identification and user authentication prior to enabling access to authorized functions.

FIA_AFL.1/AUTH.

FDP_ACC.1/TRM, FDP_ACF.1/TRM that ensure that only an authorized user under specific conditions can perform a dedicated operation, and in particular, that only users authenticated as authenticated terminal.

FDP_UCT.1/SCD, FDP_UCT.1/TRM that ensures data exchange confidentiality.

FDP_UIT.1/TRM that ensures data exchange integrity.

SF.KEY_MGT The implementation of this security function contributes to:

FCS_CKM.1/SCD/SVD_Generation that ensures cryptographic key generation.

FCS_CKM.4 that manages that ensure cryptographic key destruction.

FDP_ACC.1/SCD/SVD_Generation, FDP_ACF.1/SCD/SVD_Generation, FDP_ACC.1/SVD_Transfer, FDP_ACF.1/SVD_Transfer, FDP_ACC.1/SCD_Import, FDP_ACF.1/SCD_Import that ensure that only an authorized user under specific conditions can perform a dedicated operation, and in particular, that only users authenticated as administrator or signatory.

FDP_ITC.1/SCD that ensures a trusted channel between them TOE and a Terminal to protect the exchanged data from modification and disclosure.

FIA_UID.1, FIA_UAU.1 that provide user identification and user authentication prior to enabling access to authorized functions.

FMT_SMF.1.

FMT_MSA.2, FMT_MSA.3, FMT_MSA.4 that manage the access right policy of the TOE.

FDP_UCT.1/TRM that ensures data exchange confidentiality.

FDP_UIT.1/TRM that ensures data exchange integrity.

SF.CONF The implementation of this security function contributes to:

FMT_SMF.1.

FMT_MSA.2, FMT_MSA.3 that manage the access right policy of the TOE.

FMT_MTD.1/TOE_State that restrict the ability to switch the TOE from phase 6 to phase 7 to the personalization agent.

SF.ESERVICE The implementation of this security function contributes to:

FCS_COP.1/Digital Auth, FCS_COP.1/Enc Key Decipherment that provide cryptographic operations.

SF.SAFESTATE_MGT The implementation of this security function contributes to:

FDP_RIP.1 that ensures erasure of data in FLASH and in RAM.

FDP_SDI.2/Persistent, FDP_SDI.2/DTBS that ensure the integrity of data stored in the TOE.

FPT_FLS.1 that ensure the preservation of secure state when failures occur.

FPT_TST.1 that ensures the integrity of the data stored on the TOE.

SF.PHYS The implementation of this security function contributes to:

FPT_EMS.1, FPT_EMS.1/PIN-PUK-KEYS that ensure the TOE emanation.

FPT_PHP.1, FPT_PHP.3 that ensures the detection of physical tampering of the TOE and the resistance to it.

FMT_LIM.1, FMT_LIM.2.

9.2.2 Association tables of SFRs and TSS

Security Functional Requirements	TOE Summary Specification
FCS_CKM.1/SCD/SVD_Generation	SF.KEY_MGT
FCS_CKM.4	SF.KEY_MGT
FDP_ACC.1/SCD/SVD_Generation	SF.KEY_MGT

FDP_ACF.1/SCD/SVD_Generation	SF.KEY_MGT
FDP_ACC.1/SVD_Transfer	SF.KEY_MGT
FDP_ACF.1/SVD_Transfer	SF.KEY_MGT
FDP_ACC.1/SCD_Import	SF.KEY_MGT
FDP_ACF.1/SCD_Import	SF.KEY_MGT
FDP_RIP.1	SF.SAFESTATE_MGT
FDP_SDI.2/Persistent	SF.SAFESTATE_MGT
FDP_ITC.1/SCD	SF.KEY_MGT
FDP_UCT.1/SCD	SF.SM
FDP_DAU.2/SVD	SF.SM
FIA_UID.1	SF.PIN_MGT, SF.SIG, SF. AUTH, SF.KEY_MGT
FIA_UAU.1	SF.PIN_MGT, SF.SIG, SF. AUTH, SF.KEY_MGT
FIA_API.1	SF. AUTH, SF.SM
FMT_SMR.1	SF.PIN_MGT, SF. AUTH
FMT_SMF.1	SF.PIN_MGT, SF.SIG, SF. AUTH, SF.KEY_MGT, SF.CONF
FMT_MSA.1/Admin	SF. AUTH
FMT_MSA.2	SF.SIG, SF. AUTH, SF.KEY_MGT, SF.CONF
FMT_MSA.3	SF.SIG, SF. AUTH, SF.KEY_MGT, SF.CONF
FMT_MSA.4	SF.SIG, SF. AUTH, SF.KEY_MGT
FMT_MTD.1/Admin	SF.PIN_MGT
FPT_EMS.1	SF.PHYS
FPT_FLS.1	SF.SAFESTATE_MGT
FPT_PHP.1	SF.PHYS
FPT_PHP.3	SF.PHYS
FPT_TST.1	SF.SAFESTATE_MGT
FTP_ITC.1/SCD	SF. AUTH, SF.SM
FTP_ITC.1/SVD	SF. AUTH, SF.SM
FCS_COP.1/Sign	SF.SIG
FDP_ACC.1/Signature_Creation	SF.SIG
FDP_ACF.1/Signature_Creation	SF.SIG
FDP_SDI.2/DTBS	SF.SIG, SF.SAFESTATE_MGT
FIA_AFL.1/RAD	SF.PIN_MGT
FMT_MOF.1	SF.SIG
FMT_MSA.1/Signatory	SF.SIG
FMT_MTD.1/Signatory	SF.PIN_MGT
FCS_CKM.1/Session Keys	SF.SM
FCS_CKM.1/DH_PACE	SF. AUTH
FCS_COP.1/GP Secret Data Protection	SF. AUTH, SF.SM
FCS_COP.1/SM in Confidentiality	SF. AUTH, SF.SM
FCS_COP.1/SM in Integrity	SF. AUTH, SF.SM

FCS_COP.1/Digital Auth	SF.ESERVICE
FCS_COP.1/Enc Key Decipherment	SF.ESERVICE
FCS_COP.1/SIG_VER	SF. AUTH, SF.SM
FCS_RND.1	SF. AUTH
FIA_UID.1/PACE	SF.PIN_MGT, SF. AUTH, SF.SM
FIA_UAU.1/PACE	SF.PIN_MGT, SF. AUTH, SF.SM
FIA_UAU.4/PACE	SF.PIN_MGT, SF. AUTH, SF.SM
FIA_UAU.5/PACE	SF.PIN_MGT, SF. AUTH, SF.SM
FIA_UAU.6/PACE	SF. AUTH, SF.SM
FIA_UAU.6/EAC	SF. AUTH, SF.SM
FIA_AFL.1/AUTH	SF.PIN_MGT, SF. AUTH, SF.SM
FIA_API.1/TOE Authentication	SF. AUTH, SF.SM
FDP_ACC.1/TRM	SF. AUTH, SF.SM
FDP_ACF.1/TRM	SF. AUTH, SF.SM
FDP_UCT.1/TRM	SF. AUTH, SF.SM, SF.KEY_MGT
FDP_UIT.1/TRM	SF.SM, SF.KEY_MGT
FTP_ITC.1/PACE	SF.PIN_MGT, SF. AUTH, SF.SM
FMT_SMR.1/PACE	SF.PIN_MGT, SF. AUTH
FMT_MTD.1/CVCA_INI	SF. AUTH
FMT_MTD.1/CVCA_UPD	SF. AUTH
FMT_MTD.1/DATE	SF. AUTH
FMT_MTD.1/CAPK	SF. AUTH
FMT_MTD.1/KEY_READ	SF. AUTH
FMT_MTD.1/Initialize_PIN	SF.PIN_MGT
FMT_MTD.1/Resume_PIN	SF.PIN_MGT
FMT_MTD.1/Change_PIN	SF.PIN_MGT
FMT_MTD.1/Unblock_PIN	SF.PIN_MGT
FMT_MTD.1/UnblockChange_RAD	SF.PIN_MGT
FMT_MTD.1/Erase_PIN	SF.PIN_MGT
FMT_MTD.1/Reinitialize_PIN	SF.PIN_MGT
FMT_MTD.1/UnblockChange_PUK	SF.PIN_MGT
FMT_MTD.1/TOE State	SF.CONF
FMT_MTD.3	SF.PIN_MGT, SF. AUTH
FMT_LIM.1	SF.PHYS
FMT_LIM.2	SF.PHYS
FPT_EMS.1/PIN-PUK-KEYS	SF.PHYS

Table 16 SFRs and TSS - Coverage

TOE Summary Specification	Security Functional Requirements
---------------------------	----------------------------------

SF.PIN_MGT	FIA_UID.1/PACE, FIA_UAU.1/PACE, FIA_UAU.4/PACE, FIA_UAU.5/PACE, FIA_AFL.1/AUTH, FTP_ITC.1/PACE, FMT_SMR.1/PACE, FMT_MTD.1/Initialize_PIN, FMT_MTD.1/Resume_PIN, FMT_MTD.1/Change_PIN, FMT_MTD.1/Unblock_PIN, FMT_MTD.1/UnblockChange_RAD, FMT_MTD.1/Erase_PIN, FMT_MTD.1/Reinitialize_PIN, FMT_MTD.1/UnblockChange_PUK, FMT_MTD.3, FIA_UID.1, FIA_UAU.1, FMT_SMR.1, FMT_SMF.1, FMT_MTD.1/Admin, FIA_AFL.1/RAD, FMT_MTD.1/Signatory
SF.SIG	FIA_UID.1, FIA_UAU.1, FMT_SMF.1, FMT_MSA.2, FMT_MSA.3, FMT_MSA.4, FCS_COP.1/Sign, FDP_ACC.1/Signature_Creation, FDP_ACF.1/Signature_Creation, FDP_SDI.2/DTBS, FMT_MOF.1, FMT_MSA.1/Signatory
SF.AUTH	FCS_CKM.1/DH_PACE, FCS_COP.1/GP Secret Data Protection, FCS_COP.1/SM in Confidentiality, FCS_COP.1/SM in Integrity, FCS_COP.1/SIG_VER, FCS_RND.1, FIA_UID.1/PACE, FIA_UAU.1/PACE, FIA_UAU.4/PACE, FIA_UAU.5/PACE, FIA_UAU.6/PACE, FIA_UAU.6/EAC, FIA_AFL.1/AUTH, FIA_API.1/TOE Authentication, FDP_ACC.1/TRM, FDP_ACF.1/TRM, FDP_UCT.1/TRM, FTP_ITC.1/PACE, FMT_SMR.1/PACE, FMT_MTD.1/CVCA_INI, FMT_MTD.1/CVCA_UPD, FMT_MTD.1/DATE, FMT_MTD.1/CAPK, FMT_MTD.1/KEY_READ, FMT_MTD.3, FIA_UID.1, FIA_UAU.1, FIA_API.1, FMT_SMR.1, FMT_SMF.1, FMT_MSA.1/Admin, FMT_MSA.2, FMT_MSA.3, FMT_MSA.4, FTP_ITC.1/SCD, FTP_ITC.1/SVD
SF.SM	FCS_CKM.1/Session Keys, FCS_COP.1/GP Secret Data Protection, FCS_COP.1/SM in Confidentiality, FCS_COP.1/SM in Integrity, FCS_COP.1/SIG_VER, FIA_UID.1/PACE, FIA_UAU.1/PACE, FIA_UAU.4/PACE, FIA_UAU.5/PACE, FIA_UAU.6/PACE, FIA_UAU.6/EAC, FIA_AFL.1/AUTH, FIA_API.1/TOE Authentication, FDP_ACC.1/TRM, FDP_ACF.1/TRM, FDP_UCT.1/TRM, FDP_UIT.1/TRM, FTP_ITC.1/PACE, FDP_UCT.1/SCD, FDP_DAU.2/SVD, FIA_API.1, FTP_ITC.1/SCD, FTP_ITC.1/SVD
SF.KEY_MGT	FDP_UCT.1/TRM, FDP_UIT.1/TRM, FCS_CKM.1/SCD/SVD_Generation, FCS_CKM.4, FDP_ACC.1/SCD/SVD_Generation, FDP_ACF.1/SCD/SVD_Generation, FDP_ACC.1/SVD_Transfer, FDP_ACF.1/SVD_Transfer, FDP_ACC.1/SCD_Import, FDP_ACF.1/SCD_Import, FDP_ITC.1/SCD, FIA_UID.1, FIA_UAU.1, FMT_SMF.1, FMT_MSA.2, FMT_MSA.3, FMT_MSA.4
SF.CONF	FMT_MTD.1/TOE State, FMT_SMF.1, FMT_MSA.2, FMT_MSA.3
SF.ESERVICE	FCS_COP.1/Digital Auth, FCS_COP.1/Enc Key Decipherment
SF.SAFESTATE_MGT	FDP_RIP.1, FDP_SDI.2/Persistent, FPT_FLS.1, FPT_TST.1, FDP_SDI.2/DTBS
SF.PHYS	FMT_LIM.1, FMT_LIM.2, FPT_EMS.1/PIN-PUK-KEYS, FPT_EMS.1, FPT_PHP.1, FPT_PHP.3

Table 17 TSS and SFRs - Coverage